

# Electropneumatic Positioner Type 3730-3



With HART communication



Fig. 1 · Type 3730-3

## Mounting and Operating Instructions

**EB 8384-3 EN**

Firmware version 1.20

Edition January 2005



Contents	Page
<b>1</b>	<b>Design and principle of operation</b> . . . . . 8
1.1	Communication . . . . . 9
1.2	<b>Additional equipment</b> . . . . . 9
1.3	Technical data . . . . . 10
<b>2</b>	<b>Attachment to the control valve – mounting parts and accessories</b> . . . . . 13
2.1	Direct attachment . . . . . 16
2.1.1	Type 3277-5 Actuator . . . . . 16
2.1.2	Type 3277 Actuator . . . . . 18
2.2	Attachment according to IEC 60534-6 . . . . . 20
2.3	Attachment to Type 3510 Micro-flow Valve . . . . . 22
2.4	Attachment to rotary actuators . . . . . 24
2.5	Reversing amplifier for double-acting actuators . . . . . 26
2.6	Attaching an external position sensor . . . . . 28
2.6.1	Mounting the position sensor with direct attachment . . . . . 28
2.6.2	Mounting the position sensor with attachment according to IEC 60534-6 . . . . . 30
2.6.3	Mounting the position sensor to Type 3510 Micro-flow Valve . . . . . 31
2.6.4	Mounting the position sensor to rotary actuators . . . . . 32
<b>3</b>	<b>Connections</b> . . . . . 34
3.1	Pneumatic connections . . . . . 34
3.1.1	Signal pressure gauges . . . . . 34
3.1.2	Supply pressure . . . . . 34
3.2	Electrical connections . . . . . 36
3.2.1	Switching amplifiers . . . . . 37
3.2.2	Establishing communication . . . . . 38
<b>4</b>	<b>Operation</b> . . . . . 40
4.1	Operator controls and display . . . . . 40
4.2	Enabling and selecting parameters . . . . . 42
4.3	Operating modes . . . . . 43
4.3.1	Automatic and manual operating modes . . . . . 43
4.3.2	SAFE – Fail-safe position . . . . . 44
<b>5</b>	<b>Start-up and settings</b> . . . . . 44
5.1	Determining the fail-safe position . . . . . 44
5.2	Setting the volume restriction Q . . . . . 45
5.3	Limiting the signal pressure . . . . . 45
5.4	Checking the operating range of the positioner . . . . . 45
5.5	Initialization . . . . . 47
5.5.1	Initialization modes . . . . . 48

5.6	Start-up via local interface (SSP) . . . . .	55
5.7	Start-up over HART communication . . . . .	55
5.8	Faults . . . . .	56
5.9	Zero calibration . . . . .	56
5.10	<b>Reset to default values</b> . . . . .	<b>57</b>
<b>6</b>	<b>Adjusting the limit switch</b> . . . . .	<b>58</b>
<b>7</b>	<b>Quick start-up guide</b> . . . . .	<b>60</b>
7.1	Mounting . . . . .	60
7.2	Start-up . . . . .	61
7.3	Initialization . . . . .	62
7.3.1	Simplest method (MAX) . . . . .	62
7.3.2	Precise method (NOM) . . . . .	62
7.3.3	Manual method (MAN) . . . . .	62
<b>8</b>	<b>Retrofitting an inductive limit switch</b> . . . . .	<b>63</b>
<b>9</b>	<b>Maintenance</b> . . . . .	<b>64</b>
<b>10</b>	<b>Servicing explosion-protected devices</b> . . . . .	<b>64</b>
<b>11</b>	<b>Code list</b> . . . . .	<b>65</b>
<b>12</b>	<b>Dimensions in mm</b> . . . . .	<b>79</b>
	<b>Test certificates</b> . . . . .	<b>81</b>

### General safety instructions



- ▶ *The positioner may only be assembled, started up or operated by trained and experienced personnel familiar with the product. According to these mounting and operating instructions, trained personnel is referred to as individuals who are able to judge the work they are assigned to and recognize possible dangers due to their specialized training, their knowledge and experience as well as their knowledge of the relevant standards.*
  - ▶ *Explosion-protected versions of this positioner may only be operated by personnel who have undergone special training or instructions or who are authorized to work on explosion-protected devices in hazardous areas. Refer to section 10 on Servicing explosion-protected versions.*
  - ▶ *Any hazards that could be caused by the process medium, the operating pressure, the signal pressure or by moving parts of the control valve are to be prevented by means of the appropriate measures.*
  - ▶ *If inadmissible motions or forces are produced in the actuator as a result of the supply pressure level, it must be restricted by means of a suitable supply pressure reducing station.*
  - ▶ *Proper shipping and appropriate storage are assumed.*
  
  - ▶ **Note!** *The device with a CE marking fulfils the requirements of the Directives 94/9/EC (ATEX) and 89/336/EEC (EMC). The declaration of conformity can be viewed and downloaded on the Internet at <http://www.samson.de>.*
-

Article code		Type 3730-3	X	X	X	X	X	0	0	X	0	X	0	0	x	0
<b>Explosion protection</b>																
Without			0													
⊕ II 2 G EEx ia IIC T6/II 2 D IP 65 T 80 °C acc. to ATEX			1													
Ex ia FM/CSA			3													
⊕ II 3 G EEx na II T6 /II 3 D IP 65 T 80 °C acc. to ATEX			8													
<b>Additional equipment</b>																
Inductive limit switch	Without		0													
	With Type SJ 2-SN		1			0										
Solenoid valve SIL 4	Without		0													
	24 V DC		4													
Analog position transmitter	Without				0											
	With				1											
External position sensor	Without					0										
	With		0			1										
Diagnostics	Expert									1						
	Expert + (extended diagnostics)									2						
Housing material	Aluminum										0					
	Stainless steel 1.4581						0				1					
Positioner for special applications	Without															0
	Free of substances that impair painted surfaces															1
	Exhaust air with pneum. connection ¼ NPT															2
Special versions	Without															0

**Modifications of positioner firmware in comparison to previous versions**

Previous	New
<b>1.00</b>	<b>1.10</b>
	<p>The HART protocol as per HART specification Revision 5 is supported by default setting.                      The setting can be changed to HART Revision 6 over TROVIS-VIEW. HART tools as well as AMS or handheld communicators are currently not supported by the Revision 6 version.</p>
	<p>The following additional status indications were implemented:                      Code <b>76</b> - No emergency mode                      Code <b>77</b> - Program loading error                      Displays number of zero calibrations performed since the last initialization.</p>
	<p>For initialization of "AIR TO CLOSE" actuators, the direction of action (Code 7) is automatically set to increasing/decreasing.</p>
	<p>Code <b>3</b>, the activation period of the enabled configuration function was extended to 120 s.</p>
<b>1.10</b>	<b>1.20</b>
	<p>Electronics changed, no new functions added.</p>



### 1 Design and principle of operation

The electropneumatic positioner is mounted to pneumatic control valves and is used to assign the valve position (controlled variable  $x$ ) to the control signal (reference variable  $w$ ). The DC control signal received from a control unit is compared to the travel or rotational angle of the control valve and issues a signal pressure (output variable  $y$ ).

The positioner is designed depending on the corresponding accessories for direct attachment to Type 3277 Actuators or for attachment to actuators according to IEC 60534-6 (NAMUR).

Additionally, a coupling wheel included in the accessories is required to transfer the rotary motion for rotary actuators according to VDI/VDE 3845.

Springless rotary actuators require an accessory reversing amplifier to permit the powered operation in either direction.

The positioner basically consists of a travel sensor system that functions proportional to the resistance, an analog i/p module with downstream booster as well as the electronic unit with a microcontroller.

The positioner is fitted with three binary contacts as standard: A fault alarm output is used to indicate a fault to the control station and two configurable software limit switches to indicate the valve's end positions.

The position of the valve is transmitted as linear travel motion or angle of rotation via pick-up lever and travel sensor (2) to an analog PD controller (3). Simultaneously, an A/D converter (4) transmits the position of the valve to the microcontroller (5). The PD

controller compares this actual position to the 4 to 20 mA DC control signal (reference variable) after it has been converted by the A/D converter (4).

In case of a system deviation, the operation of the i/p converter (6) is changed so that the actuator (1) is filled or vented via the downstream air capacity booster (7). This causes the closure member of the control valve to move to the position determined by the reference variable.

The pneumatic air capacity booster (7) and the pressure regulator (8) are provided with supply air. An intermediate flow regulator (9) with fixed settings is used to purge the positioner and also guarantees trouble-free operation of the pneumatic booster. The output signal pressure supplied by the booster can be limited over the software.

The volume restriction  $Q$  (10) is used to optimize the positioner by adapting it to the actuator size.

#### Serial interface

The positioner is equipped with an interface to allow the SAMSON TROVIS-VIEW Configuration and Operator Interface software to transmit data and parameters over an adapter cable from the RS-232 interface of a computer to the positioner.



### 1.1 Communication

The positioner is equipped with an interface for HART protocol (Highway Addressable Remote Transducer) for communication purposes. Data are transmitted in a superimposed frequency (FSK = Frequency Shift Keying) on the existing signal loop for the 4 to 20 mA reference variable.

Either a HART capable handheld communicator or a PC with FSK modem can be used to establish communication and operate the positioner.

### 1.2 Additional equipment

As an option, the device can be additionally equipped with a solenoid valve for forced venting, an analog position transmitter, an inductive limit switch or an external position sensor.

#### Version with solenoid valve

If the operating voltage for the solenoid valve (12) fails, the supply pressure for the i/p module is vented to the atmosphere. The positioner can no longer operate and the control valve moves to the fail-safe position determined by the actuator, independent of the reference variable.

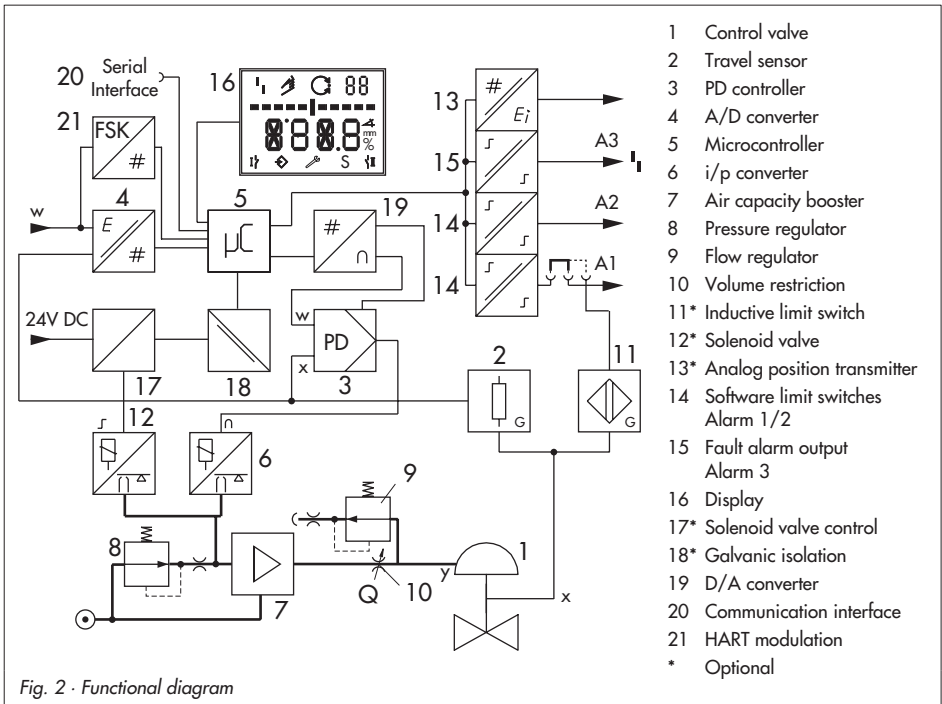

Fig. 2 · Functional diagram

### Positioner with position transmitter

The position transmitter (13) is a two-wire transmitter and issues the travel sensor signal as a 4 to 20 mA signal processed by the microcontroller.

Since this signal is issued independent of the positioner's input signal (min. current 3.8 mA), the actual travel/angle of rotation is controlled in real-time. Additionally, the position transmitter provides the possibility of signaling a positioner fault over a signal current of <2.4 mA or >21.6 mA.

### Version with inductive limit switch

The rotary shaft of the positioner carries an adjustable tag which actuates the installed proximity switch.

The optional inductive limit switch (11) leads to A1 and the software limit switch, which remains in operation, leads to A2.

### Version with external position sensor

In this version, only the sensor is mounted to the control valve. The positioner is located separately from the valve.

The connection of x and y signals to the valve is established via cable and air hosing (only for non-hazardous areas and without inductive limit switch).

## 1.3 Technical data

Positioner	
Nominal travel, adjustable	Direct attachment to Type 3277: 3.6 to 30 mm, attachment acc. to IEC 60534-6: 3.6 to 200 mm or 24° to 100° opening angle for rotary actuators
Travel range	Adjustable within the nominal travel/nominal angle, max. ratio 1 : 5
Reference variable w	Signal range 4 to 20 mA, 2-wire unit, reverse polarity protection, min. span 4 mA, static destruction limit 100 mA
Minimum current	3.6 mA for display, 3.8 mA for operation
Load impedance	Version without explosion protection: ≤ 6 V (corresponding to 300 Ω at 20 mA), Explosion-protected version: ≤ 7 V (corresponding to 350 Ω at 20 mA)
Supply air	Supply pressure from 1.4 to 6 bar (20 to 90 psi), Air quality acc. to ISO 8573-1: Max. particle size and density: Class 4 Oil content: Class 3, pressure dew point: Class 3 or at least 10 K beneath the lowest ambient temperature to be expected
Signal pressure (output)	0 bar up to supply pressure, limitable to 1.4/2.4/3.7 ± 0.2 bar via software
Characteristic, user-defined adjustable over operating software	Linear/equal percentage/reverse equal percentage/butterfly valve linear/ butterfly valve eq. percentage/rotary plug valve linear/rotary plug valve eq. percentage/segmented ball valve linear/segmented ball valve eq. percentage Deviation from terminal-based conformity ≤ 1 %
Hysteresis	≤ 0.3 %
Sensitivity	≤ 0.1 %

Transit time	Separately adjustable up to 240 seconds for supply air and exhaust air	
Direction of action	Reversible	
Air consumption, steady state	Independent from supply pressure approx. 110 l <sub>n</sub> /h	
Air delivery Actuator pressurized Actuator vented	At Δp = 6 bar: ≥ 8.5 m <sub>n</sub> <sup>3</sup> /h, at Δp = 1.4 bar: 3.0 m <sub>n</sub> <sup>3</sup> /h K <sub>Vmax</sub> (20 °C) = 0.09 at Δp = 6 bar: ≤ 14.0 m <sub>n</sub> <sup>3</sup> /h, at Δp = 1.4 bar: 4.5 m <sub>n</sub> <sup>3</sup> /h K <sub>Vmax</sub> (20 °C) = 0.15	
Permissible ambient temperature	-20 to +80 °C, with metal cable gland -40 to +80 °C The limits specified in the EC Type Examination Certificate additionally apply for explosion-protected devices.	
Influences	Temperature: ≤ 0.15 %/10 K Supply air: None Vibration: ≤ 0.25 % up to 2000 Hz and 4 g acc. to IEC 770	
Electromagnetic compatibility	Complying with EN 61000-6-2, EN 61000-6-3 and NAMUR Recommendation NE 21	
Explosion protection	⊕ II 2 G EEx ia IIC T6 / II 2 D IP 65 T 80 °C or ⊕ II 3 G EEx nA II T6 / II 3 D IP 65 T 80 °C	
Degree of protection	IP 65	
<b>Communication</b> (local)	SAMSON SSP interface and serial interface adapter	
Software requirements	TROVIS-VIEW with database module 3730-3	
<b>Communication</b> (HART)	HART® field communication protocol Impedance in the HART frequency range: receive 350 to 450 Ω, send: approx. 155 Ω	
Software requirements (HART)	For handheld communicator: device description for 3730-3, For PC: DTM file acc. to Specification 1.2, suitable for integrating the positioner in frame applications that supports the FDT/DTM concept (e.g. PACTware); other integration options (e.g. AMS,, PDM) available.	

<b>Binary contacts</b>	1 fault alarm contact, 2 software limit switches with configurable limit values, reverse polarity protection	
Signal status No response: Response:	<b>Without explosion protection</b> Conductive (R = 348 Ω) Non-conducting	<b>Ex.-protected version:</b> ≥ 2.1 mA ≤ 1.2 mA
Operating voltage	Positioners with model no. ../9000 only for connection to signal converter acc. to EN 60947-5-6. All other versions also for connection to binary input of the PLC acc. to EN 61131, P <sub>max</sub> = 400 mW	Only for connection to signal converter acc. to EN 60 957-5-6

## Design and principle of operation

<b>Solenoid valve</b>	SIL 4 approval acc. to IEC 61508
Input	24 V DC reverse polarity protection, static destruction limit 40 V; Current consumption $I = \frac{U - 5.6 \text{ V}}{4020 \text{ W}}$ (corresponding to 4.5 mA at 24 V)
Signal	Signal "0" no pick-up $\leq 15 \text{ V}$ Signal "1" safe pick-up $>19 \text{ V}$
Service life	$>2 \times 10^7$ switching cycles
Implementation in safety-relevant systems in compliance with IEC 61508	Probability of failure on demand of safety functions PFD $< 2.8 \times 10^{-7}$ for a confidence level of 95 %. The safe failure fraction (SFF) according to Table A1 in IEC 61508-2 is greater or equal to 0.99. The valves are therefore suitable for implementation in safety-related systems with a hardware fault tolerance of 1 or 2 up to and including SIL 4.
<b>Analog position transmitter</b>	Two-wire transmitter
Supply voltage	12 to 30 V DC, reverse polarity protection, static destruction limit 40 V
Output signal	4 to 20 mA
Direction of action	Reversible
Operating range	0 to 100 % of the travel range, optional also for fault indication over 2.4 or 21.6 mA
Characteristic	Linear
Hysteresis and HF influence	Same as positioner
Ripple content of output signal	0.6 % at 28 Hz acc. to IEC 381 T1
Other influences	Same as positioner
Fault indication	Can be issued with current signal $< 2.4 \text{ mA}$ or $> 21.6 \text{ mA}$
<b>Inductive limit switch</b>	Type SJ 2SN Proximity Switch
For connection to switching amplifier acc. to EN 60947-5-6. Can be used in combination with a software limit switch.	
<b>External position sensor</b>	
Nominal travel	Adjustable same as positioner
Cable	Max. 10 m with M12x1 connector, designed for continuous flexing, flame retardant acc. to VDE 0472, resistant to oils, lubricants as well as other corrosive media
Ambient conditions	Perm. temperature: $-40$ to $+105 \text{ }^\circ\text{C}$ , the limits specified in the EC Type Examination Certificate additionally apply for explosion-protected devices. Vibration immunity: up to 10 g in the range between 10 and 2000 Hz
Degree of protection	IP 67
<b>Materials</b>	Housing: Die-cast aluminum GD AlSi12 acc. to DIN 1725 (3.2582), chromated and plastic coated, special version. CrNiMo (1.4581); External parts: Stainless steel 1.4571 and 1.4301. Cable gland M20x1.5, black polyamide
<b>Weight</b>	Approx. 1.0 kg

## 2 Attachment to the control valve – mounting parts and accessories

The positioner can be attached either directly to a SAMSON Type 3277 Actuator or according to IEC 60534-6 (NAMUR) to control valves with cast yokes or rod-type yokes as well as to rotary actuators according to VDI/VDE 3845.

For attachment to the various actuators, corresponding mounting parts and accessories are required. These are listed with their order numbers in Tables 1 to 5.

On attaching the positioner, it is important to observe the assignment between lever and pin position according to the travels listed in the travel tables.

The tables show the maximum adjustment range at the positioner. The travel that can be implemented at the valve is restricted by the pin position used and additionally by the actuator spring compression required. The positioner is standard equipped with the lever **M** (pin position **35**).

### Note!

*If the standard mounted lever M (pin position 35) is replaced, the newly mounted lever must be moved once all the way as far as it will go in both directions to adapt it to the internal measuring lever.*

Travel table for direct attachment to Type 3277 Actuator								
Type 3277-5 and 3277 Actuators	Actuator size	Rated travel	Adjustment range at positioner		Required lever	Assigned pin position		
	cm <sup>2</sup>	mm	Min.	Travel Max.				
		120	7.5	5	17.6	M	25	
		120/240/350	15	7.5	35.4	M	35	
	700	30	10	50	M	50		
Travel table for attachment according to IEC 60534-6 (NAMUR)								
Type 3271 Actuator	SAMSON valves		Other valves/actuators			Required lever	Assigned pin position	
	cm <sup>2</sup>	Rated travel mm	Min.	Travel	Max.			
	60 and 120 with Type 3510 Valve	7.5	3.6		17.6	S	17	
	120	7.5	5.0		17.6	M	25	
	120/240/350	15	7.5		35.4	M	35	
	700/1400/2800	15 and 30/30	10		50	M	50	
	1400/2800	60	14.0		70.8	L	70	
	1400/2800	60	20.0		100	L	100	
2800	120	40.0		200	XL	200		
Rotary actuators					Opening angle 24° to 100°		M	90°

## Attachment to the control valve – mounting parts and accessories

Table 1		Direct attachment to Type 3277-5 Actuator		Order no.
Mounting parts	For actuators with 120 cm <sup>2</sup> effective diaphragm area			1400-7452
Accessories for the actuator	Switchover plate (old) for Actuator Type 3277-5xxxxxx.00 (old)			1400-6819
	Switchover plate <b>new</b> for Actuator Type 3277-5xxxxxx.01 (new)			1400-6822
	Connecting plate for additional attachment of a solenoid valve G 1/8			1400-6820
	Connecting plate (old) for Actuator Type 3277-5xxxxxx.00 (old) 1/8 NPT			1400-6821
	Connecting plate <b>new</b> for Actuator Type 3277-5xxxxxx.01 (new)			1400-6823
<b>Note:</b> Only new switchover and connecting plates can be used with new actuators (Index 01). Old and new plates are not interchangeable.				
Accessories for the positioner	Connecting plate (6)	G ¼: 1400-7461	¼ NPT: 1400-7462	
	or pressure gauge bracket (7)	G ¼: 1400-7458	¼ NPT: 1400-7459	
	Pressure gauge mounting kit (8) (output/supply)	St. st./Bs: 1400-6950	St. st./St. st.: 1400-6951	

Table 2		Direct attachment to Type 3277 Actuator		
Accessories	Mounting parts for actuators with 240, 350 and 700 cm <sup>2</sup> , see Fig. 4			1400-7453
	Required piping with screw fittings for "Actuator stem retracts" or when the top diaphragm chamber is filled with air	cm <sup>2</sup>	Steel	Stainless steel
		240	1400-6444	1400-6445
		350	1400-6446	1400-6447
	700	1400-6448	1400-6449	
Connection block with seals and screw	G ¼: 1400-8811	¼ NPT: 1400-8812		
Pressure gauge mounting kit (output and supply)	St.st./Bs: 1400-6950	St.st./St.st.: 1400-6951		

Table 3		Attachment to NAMUR ribs or control valves with rod-type yokes (rod diameter Ø 35 mm or smaller) according to IEC 60534-6, see Fig. 5		
Travel in mm	Lever	For actuators		Order no.
7.5	S	Type 3271-5 Actuator with 60/120 cm <sup>2</sup> on Type 3510 Valve, see Fig. 6		1400-7457
5 to 50	Without (lever M on basic model)	Actuators from other manufacturers and Type 3271 with 120 to 700 cm <sup>2</sup>		1400-7454
14 to 100	L	Actuators f. other manufacturers and Type 3271 w. 1400 cm <sup>2</sup>		1400-7455
40 to 200	XL	Actuators from other manufacturers and Type 3271 with 2800 cm <sup>2</sup> , 120 mm travel		1400-7456
30 or 60	L	Type 3271 Actuator with 2800 cm <sup>2</sup> and 30 or 60 mm travel		1400-7466
Mounting brackets for Emerson and Masonellan linear actuators In addition, a mounting kit acc. to IEC 60534-6 is required depending on the travel. See row above.				1400-6771
Accessories	Connecting plate	G ¼: 1400-7461	¼ NPT : 1400-7462	
	or pressure gauge bracket (7)	G ¼: 1400-7458	¼ NPT: 1400-7459	
	Pressure gauge mounting kit (output/supply)	St.st./Bs: 1400-6950	St.st./St.st.: 1400-6951	

<b>Table 4</b> Attachment to rotary actuators (VDI/VDE 3845 for all sizes of fixing level 2) see Figs. 7 and 8			
Mounting parts	With follower clamp and coupling wheel	VDI/VDE 3845 for all sizes of fixing level 2 for Type 3278 Actuator with 160/320 cm <sup>2</sup> for Camflex II	1400-7448 1400-7614 1400-9120
Accessories	Connecting plate	G ¼: 1400-7461      ¼ NPT: 1400-7462	
	or pressure gauge bracket (7)	G ¼: 1400-7458      ¼ NPT: 1400-7459	
	Pressure gauge mounting kit (output/supply)	St.st./Bs: 1400-6950      St.st./St.st: 1400-6951	
<b>Table 5</b> General accessories			
Accessories	Pneumatic reversing amplifier for double-acting actuators	G ¼ ¼ NPT	1079-1118 1079-1119
	Cable gland M20 x 1.5      Nickel-plated brass		1890-4875
	Adapter M 20 x 1.5 to ½ NPT, aluminum		0310-2149
	Retrofit kit for inductive limit switch 1x SJ 2-SN		1400-7460
	Cover plate with list of parameters and operating instructions	German/English (standard) English/Spanish English/French	1190-0761 1190-3100 1190-3142

## 2.1 Direct attachment

### 2.1.1 Type 3277-5 Actuator

Refer to Table 1 on page 14 for the required mounting parts as well as the accessories with their order numbers.

Note the travel table on page 13!

#### Actuator with 120 cm<sup>2</sup>

Depending on the type of positioner attachment, the signal pressure is routed either left or right of the yoke through a bore to the actuator diaphragm. Depending on the fail-safe action of the actuator "Actuator stem extends" or "Actuator stem retracts" (valve closes or opens if the supply air fails), the switchover plate (9) must first be attached to the actuator yoke. Align the switchover plate with the corresponding symbol for left or right attachment according to the marking (view looking onto the switchover plate).

1. Mount connecting plate (6) or pressure gauge bracket (7) with pressure gauges onto the positioner, making sure both seal rings (6.1) are seated properly.
2. Remove vent plug (4) on the back of the positioner and close the signal pressure output "Output 38" on the connecting plate (6) or on the pressure gauge bracket (7) with the stopper (5) included in the accessories.
3. Place follower clamp (3) on the actuator stem, align and screw tight so that the mounting screw is located in the groove of the actuator stem.
4. Mount cover plate (10) with narrow side of the cut-out opening (Fig. 3, on the

left) pointing towards the signal pressure connection. Make sure that the bonded gasket (14) points towards the actuator yoke.

5. **15 mm travel:** Keep the follower pin (2) at lever **M** (1) on the back of the positioner in the pin position **35** (delivered state).

**7.5 mm travel:** Remove the follower pin (2) from the pin position **35**, reposition it in the bore for pin position **25** and screw tight.

6. Insert formed seal (15) in the groove of the positioner casing.
7. Place positioner on the cover plate (10) in such a manner that the follower pin (2) rests on the top of the follower clamp (3). Adjust the lever (1) correspondingly and open the positioner cover to hold the positioner shaft in position at the cap or the switch (Fig. 18).

The lever (1) must rest on the follower clamp with spring force.

Mount the positioner on the cover plate (10) using the two fixing screws. During the installation make sure that the seal ring (10.1) is inserted in the bore of the intermediate plate.

8. Mount cover (11) on the other side. Make sure that the vent plug points downwards when the control valve is installed to allow any condensed water that collects to drain off.



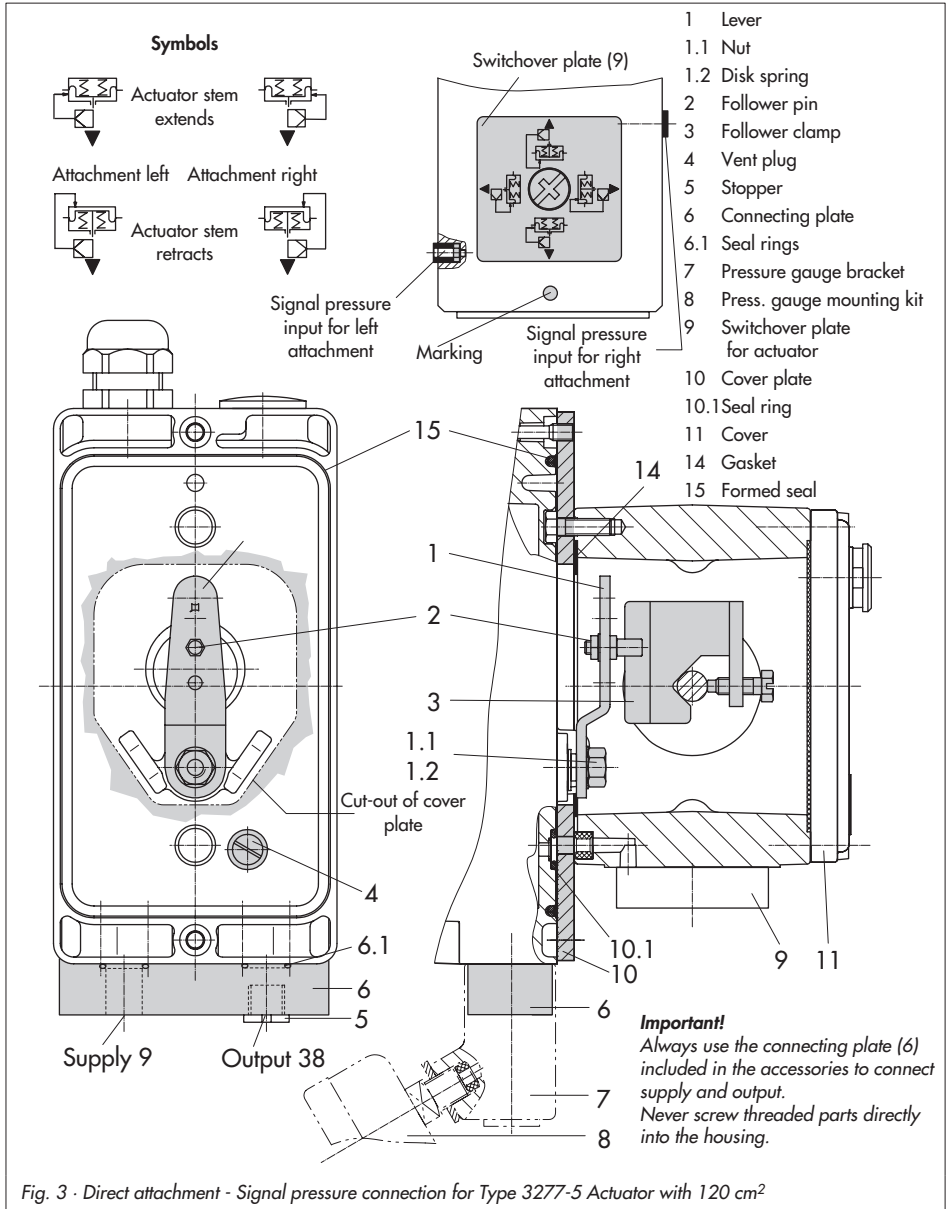

Fig. 3 · Direct attachment - Signal pressure connection for Type 3277-5 Actuator with 120 cm<sup>2</sup>

## 2.1.2 Type 3277 Actuator

Refer to Table 2 on page 14 or the required mounting parts as well as the accessories with their order numbers.

Note the travel table on page 13!

### Actuators with 240 to 700 cm<sup>2</sup>

The positioner can be mounted either on the left or on the right side of the yoke. The signal pressure is routed to the actuator over the connection block (12), for actuators with fail-safe action "Actuator stem extends" internally through a bore in the valve yoke and for "Actuator stem retracts" through external piping.

- Place follower clamp (3) on the actuator stem, align and screw tight so that the mounting screw is located in the groove of the actuator stem.
- Mount cover plate (10) with narrow side of the cut-out opening (Fig. 4, on the left) pointing towards the signal pressure connection. Make sure that the bonded gasket (14) points towards the actuator yoke.
- For actuators with 700 cm<sup>2</sup>, remove the follower pin (2) at lever **M** (1) on the back of the positioner from pin position **35**, reposition it in the bore for pin position **50** and screw tight.  
For actuators 240 and 350 cm<sup>2</sup> with 1.5 mm travel, the follower pin (2) remains in pin position **35**.
- Insert formed seal (15) in the groove of the positioner casing.
- Place positioner on the cover plate in such a manner that the follower pin (2) rests on the top of the follower clamp (3). Adjust the lever (1) correspondingly and open the positioner cover to hold the positioner shaft in position at the cap or the switch (Fig. 18). The lever (1) must rest on the follower clamp with spring force. Mount the positioner on the cover plate (10) using the two fixing screws.
- Make sure that the tip of the gasket (16) projecting from the side of the connection block (12) is positioned above the actuator symbol that corresponds with the actuator with fail-safe action "Actuator stem extends" or "Actuator stem retracts." If necessary, remove the three fixing screws and the cover. Then reposition the gasket (16) turned by 180°. The previous version of the connection block (Fig. 4, bottom) requires the switch plate (13) to be turned such that the corresponding actuator symbol points to the marking.
- Place the connection block (12) with the associated seal rings against the positioner and the actuator yoke. Screw it tight using the fixing screw (12.1). For actuators with fail-safe action "Actuator stem retracts", additionally remove the stopper (12.2) and fit on the external signal pressure piping.
- Mount cover (11) on the other side. Make sure that the vent plug points downwards when the control valve is installed to allow any condensed water that collects to drain off.

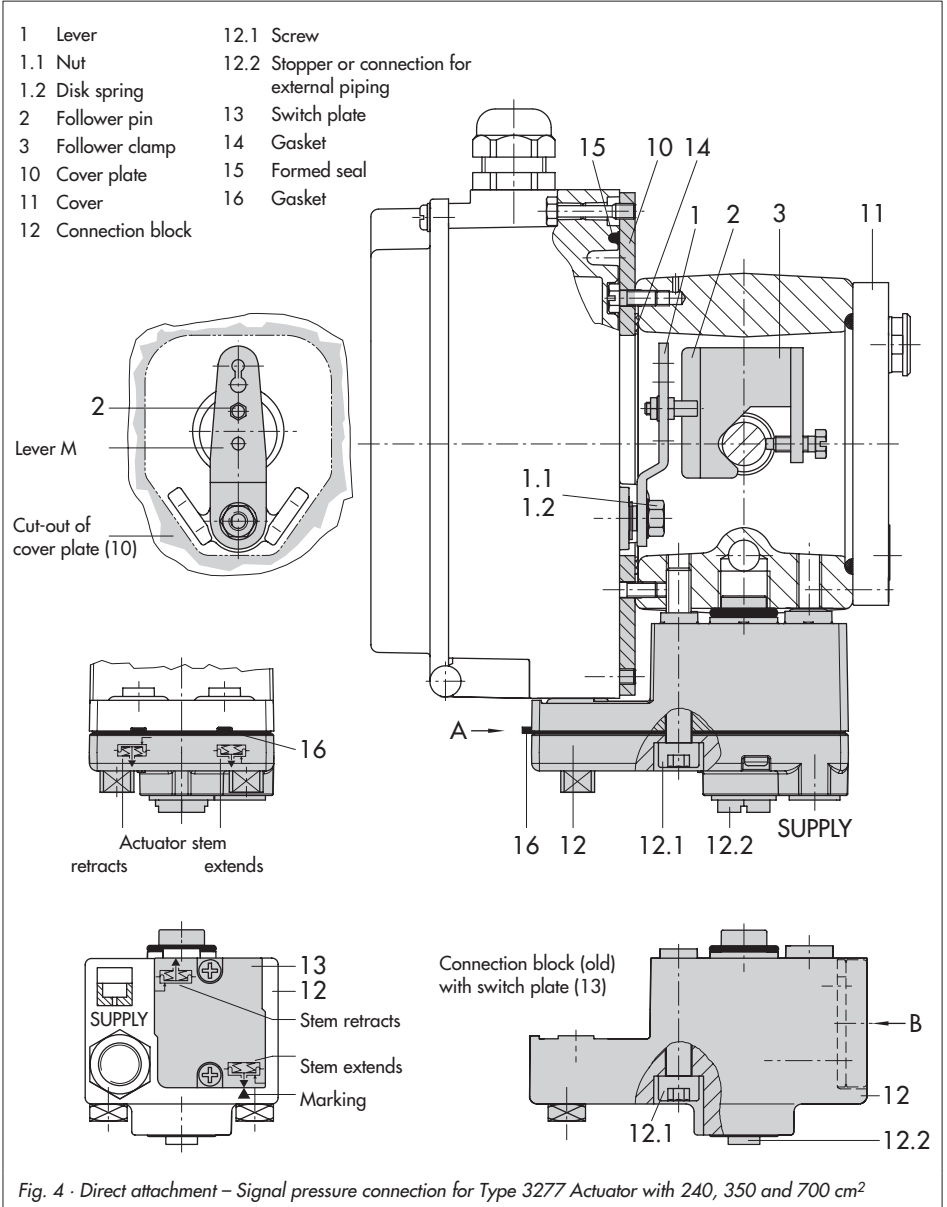

## 2.2 Attachment according to IEC 60534-6

The positioner is attached to the control valve with a NAMUR bracket (10).

---

*Refer to Table 3 on page 14 for the required mounting parts as well as the accessories with their order numbers.*

*Note the travel table on page 13!*

---

1. Screw the two bolts (14) to the bracket (9.1) of the stem connector (9), place the follower plate (3) on top and use the screws (14.1) to tighten.

### **Actuator size 2800 cm<sup>2</sup>:**

For a travel of 60 mm or smaller, screw the longer follower plate (3.1) directly to the stem connector (9). For a travel exceeding 60 mm, mount the bracket (16) first and then the follower plate (3) to the bracket together with the bolts (14) and screws (14.1).

2. Mount NAMUR bracket (10) to the control valve as follows:

For attachment to the NAMUR rib, use an M8 screw (11) and toothed lock washer directly in the yoke bore.

For attachment to valves with rod-type yokes, use two U-bolts (15) around the yoke.

Align the NAMUR bracket (10) according to the embossed scale so that the slot of the follower plate (3) is centrally aligned with the NAMUR bracket at mid valve travel.

3. Mount connecting plate (6) or pressure gauge bracket (7) with pressure gauges (8) on the positioner, making sure both seal rings (6.1) are seated properly.
4. Select required lever size (1) **M**, **L** or **XL** and pin position according to the actuator size and valve travels listed in the table below.  
Should you require a pin position other than position **35** with the standard installed lever **M**, or require a lever size **L** or **XL**, proceed as follows:
5. Screw the follower pin (2) in the assigned lever bore (pin position) as listed in the table. Only use the longer follower pin (2) included in the mounting kit.
6. Place lever (1) on the positioner shaft and screw tight using the disk spring (1.2) and nut (1.1).

---

### **Note!**

*If you have mounted a new lever (1), you must move it once all the way as far as it will go in both directions.*

---

7. Place positioner on the NAMUR bracket in such a manner that the follower pin (2) rests in the slot of the follower plate (3, 3.1). Adjust the lever (1) correspondingly.  
Screw the positioner to the NAMUR bracket using both its fixing screws.

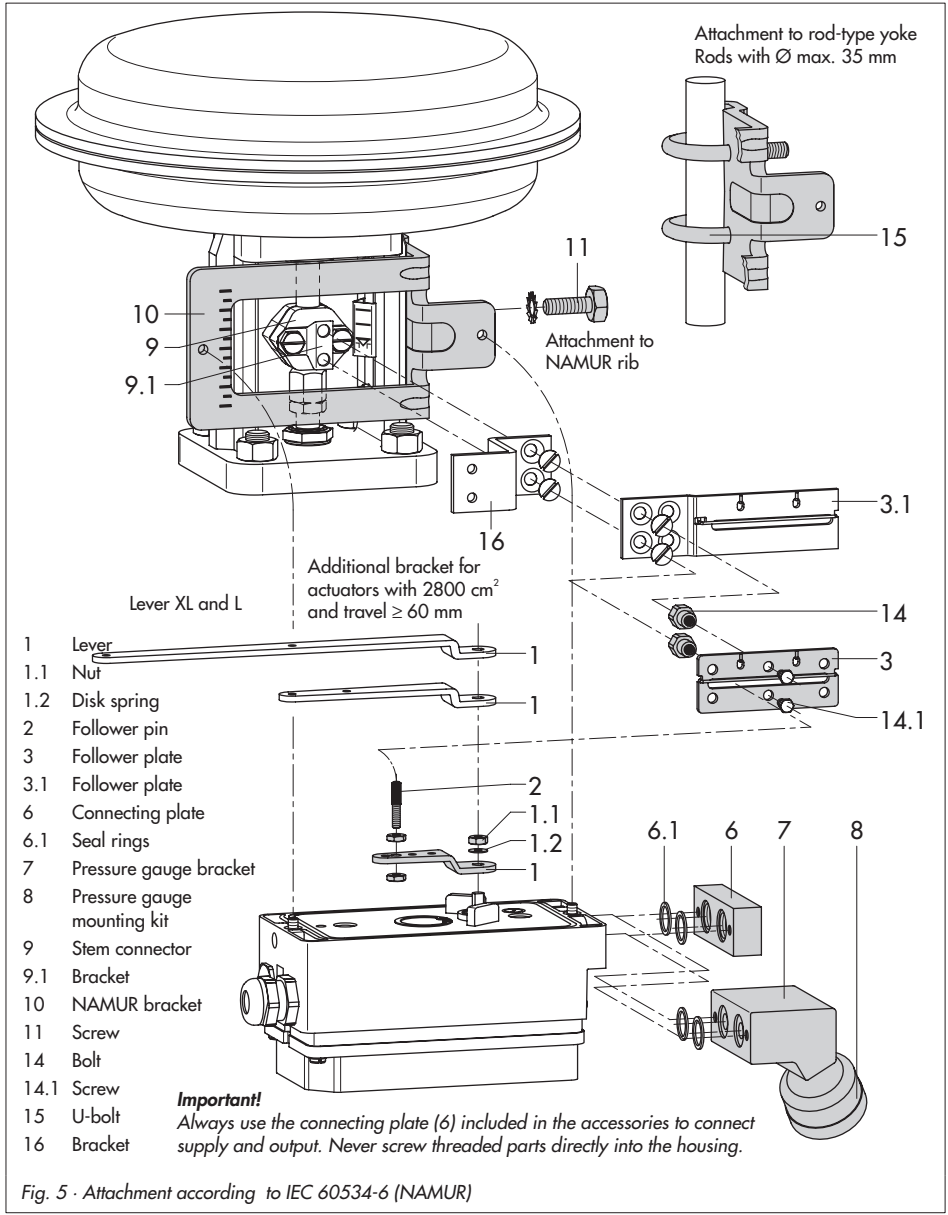

Fig. 5 · Attachment according to IEC 60534-6 (NAMUR)

## 2.3 Attachment to Type 3510 Micro-flow Valve

The positioner is attached to the valve yoke using a bracket.

---

*Refer to Table 3 on page 14 for the required mounting parts as well as the accessories with their order numbers.*

*Note the travel table on page 13!*

---

1. Place clamp (3) on the valve stem connector, align at a right angle and screw tight.
2. Screw bracket (10) to the valve yoke using two screws (11).
3. Mount connecting plate (6) or pressure gauge bracket (7) with pressure gauges to the positioner, making sure both seal rings (6.1) are seated properly.
4. Unscrew the standard installed lever **M** (1) including follower pin (2) from the positioner shaft.
5. Take lever **S** (1) and screw follower pin (2) in the bore for pin position **17**.
6. Place lever S on the positioner shaft and screw tight using the disk spring (1.2) and nut (1.1).  
Move lever once all the way as far as it will go in both directions.
7. Place positioner on the bracket (10) in such a manner that the follower pin slides into the groove of the clamp (3). Adjust the lever (1) correspondingly. Screw the positioner to the bracket (10) using both its hexagon screws.

- 1 Lever
- 1.1 Nut
- 1.2 Disk spring
- 2 Follower pin
- 3 Clamp
- 6 Connecting clamp
- 6.1 Seal rings
- 7 Pressure gauge bracket
- 8 Pressure gauge mounting kit
- 10 Bracket
- 11 Screw

**Important!**

Always use the connecting plate (6) included in the accessories to connect supply and output.  
Never screw threaded parts directly into the housing.

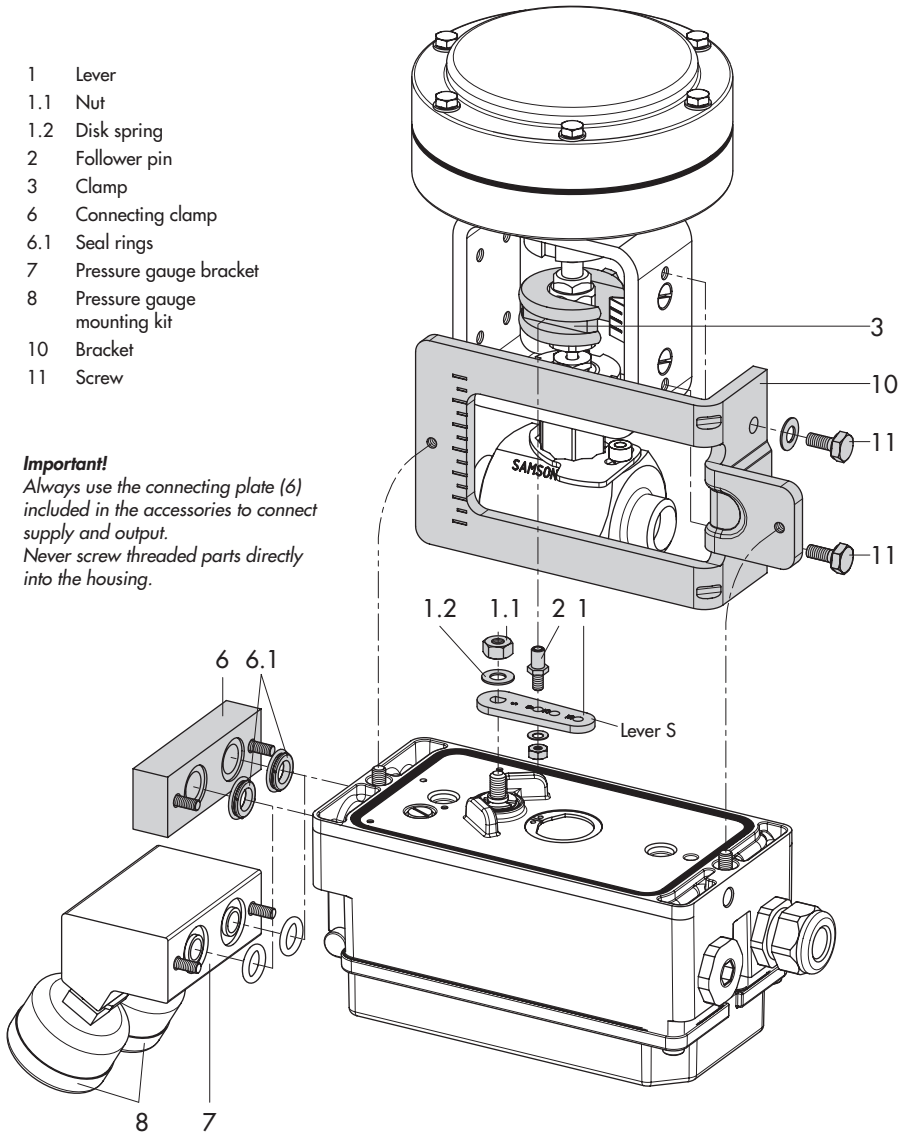

Fig. 6 · Attachment to Type 3510 Micro-flow Valve

## 2.4 Attachment to rotary actuators

The positioner is mounted to the rotary actuator using two pairs of double brackets.

Refer to Table 4 on page 15 for the required mounting parts as well as the accessories with their order numbers.

Prior to the attachment of the positioner to the SAMSON Type 3278 Rotary Actuator, you have to mount the associated adapter (5) to the free end of the rotary actuator shaft.

### Note!

During the installation of the positioner as described below, it is imperative that the actuator's direction of rotation be observed.

1. Place follower clamp (3) on the slotted actuator shaft or the adapter (5).
2. Place coupling wheel (4) with flat side facing the actuator on the follower clamp (3). Refer to Fig. 8 to align slot with the direction of rotation when the valve is in its closed position.
3. Screw coupling wheel and follower clamp tightly onto the actuator shaft using screw (4.1) and disk spring (4.2).
4. Screw the bottom pair of brackets (10.1) with the bends pointing either to the inside or to the outside (depending on the actuator size) to the actuator case. Position top pair of brackets (10) and screw tight.

5. Mount connecting plate (6) or pressure gauge bracket (7) with pressure gauges to the positioner, making sure both O-rings are seated properly. For **double-acting**, springless rotary actuators, a reversing amplifier is required to attach the positioner to the actuator, see section 2.5.
6. Unscrew the standard follower pin (2) from the positioner's lever **M** (1). Use the metal follower pin (Ø5) included in the mounting kit and screw tight into the bore for pin position **90°**.
7. Place positioner on the top pair of brackets (10) and screw tight. Considering the actuator's direction of rotation, adjust lever (1) so that it engages in the slot of the coupling wheel (4) with its follower pin (see Fig. 8). It must be guaranteed that the lever (1) is parallel to the long side of the positioner when the actuator is at half its angle of rotation.
8. Stick scale plate (4.3) on the coupling wheel so that the arrow tip indicates the closed position, and it can be easily read when the valve is installed.

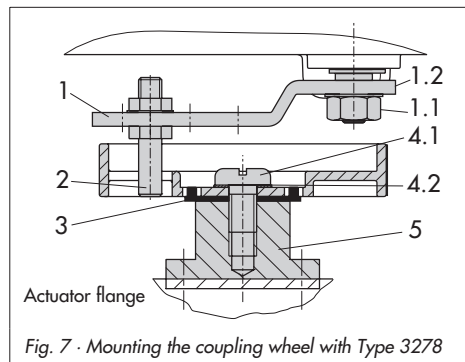

Fig. 7 · Mounting the coupling wheel with Type 3278



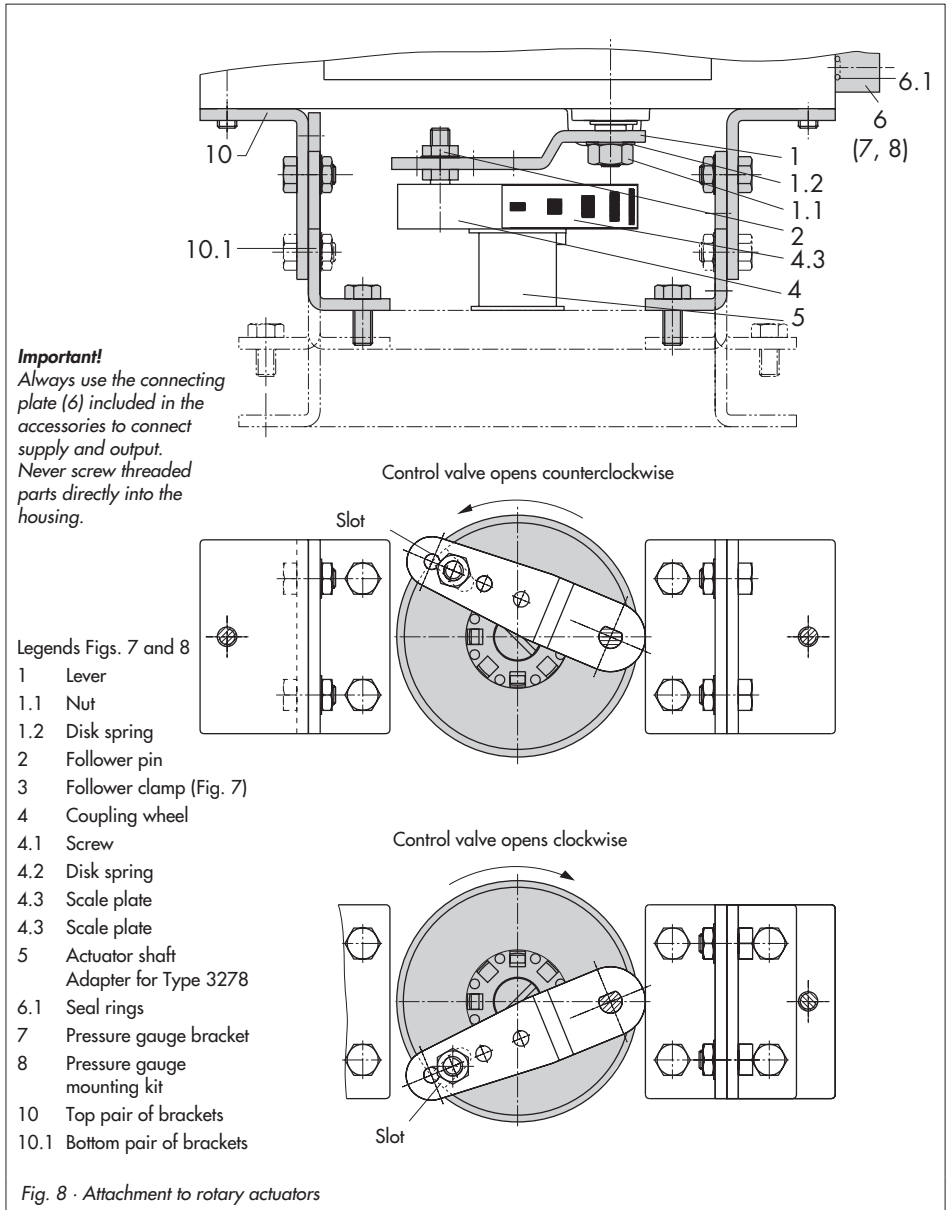

Fig. 8 · Attachment to rotary actuators

## 2.5 Reversing amplifier for double-acting actuators

For the use with double-acting actuators, the positioner must be fitted with a reversing amplifier. The reversing amplifier is listed as an accessory in the Table 5 on page 15.

The output signal pressure of the positioner is supplied at the output **A<sub>1</sub>** of the reversing amplifier. An opposing pressure, which equals the required supply pressure when added to the pressure at **A<sub>1</sub>**, is applied at output **A<sub>2</sub>**.

The rule **A<sub>1</sub> + A<sub>2</sub> = Z** applies.

### Mounting

1. Mount the connecting plate (6) from the accessories in Table 5 to the positioner. Make sure that both O-rings (6.1) are seated correctly.
2. Thread the special nuts (1.3) from the accessories of the reversing amplifier into the boreholes of the connecting plate.
3. Insert the gasket (1.2) into the recess of the reversing amplifier and push both the hollowed special screws (1.1) into the connecting boreholes **A<sub>1</sub>** and **Z**.
4. Place the reversing amplifier onto the connecting plate (6) and screw tight using both the special screws (1.1).
5. Use a screwdriver (8 mm wide) to screw the enclosed filters (1.6) into the connecting boreholes **A<sub>1</sub>** and **Z**.

---

### Note!

*The sealing plug (1.5) in the Type 3730 Positioner should not be unscrewed out of the reversing amplifier.*

*The rubber seal (1.4) is not required and can be removed when the sealing plug is used.*

---

### Signal pressure connections

**A<sub>1</sub>**: Output **A<sub>1</sub>** leading to the signal pressure connection at the actuator which opens the valve when the pressure increases

**A<sub>2</sub>**: Output **A<sub>2</sub>** leading to the signal pressure connection at the actuator which closes the valve when the pressure increases

- ▶ Set slide switch on positioner to **AIR TO OPEN**.

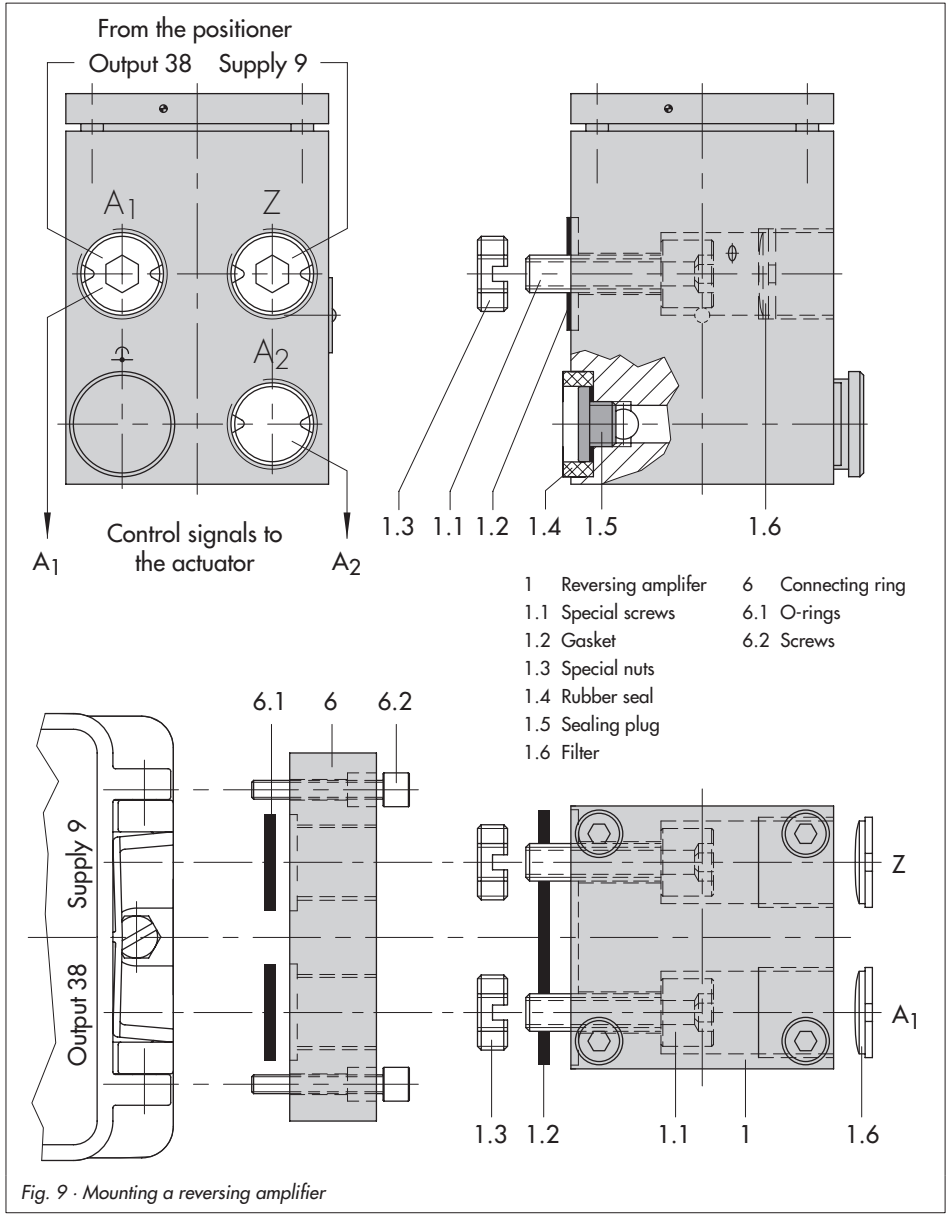

Fig. 9 · Mounting a reversing amplifier

## 2.6 Attaching an external position sensor

Refer to Table 6 on page 33 for a list of the mounting parts as well as the accessories required for mounting the position sensor. Accessories for the pneumatic connection to the positioner housing can be found in Table 7.

In the positioner version with an external position sensor, the sensor placed in a separate housing is attached over a plate or bracket to the control valve. The travel pick-off corresponds to that of a standard device.

The positioner unit can be mounted as required to a wall or a pipe.

**For the pneumatic connection** either a connecting plate (6) or a pressure gauge bracket (7) must be fixed to the housing, depending on the accessory chosen. Make sure the seal rings (6.1) are correctly inserted (see Fig. 5, bottom right).

**For the electric connection** the connecting lead must be fitted with an M12x1 connector plug at one end. The lead end without the plug can be shortened, if required, and wired to the connector included (section 3.2 on page 36). The electrical and pneumatic connections between the sensor and the positioner unit may be a maximum of 10 meters.

**Note!** In addition, the instructions in section 3.1 and 3.2 apply for the pneumatic and electrical connection.

Operation and setting are described in sections 4 and 5.

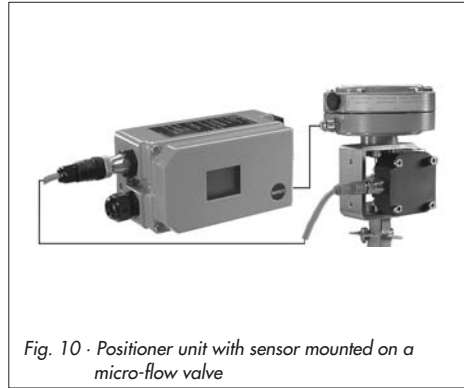

Fig. 10 · Positioner unit with sensor mounted on a micro-flow valve

### 2.6.1 Mounting the position sensor with direct attachment

#### Type 3277-5 Actuator with 120 cm<sup>2</sup>

The signal pressure from the positioner is routed over the signal pressure connection of the connecting plate (9, Fig. 11 left) to the actuator diaphragm chamber. To proceed, first screw the connecting plate (9) included in the accessories onto the actuator yoke.

- ▶ Turn the connecting plate (9) so that the correct symbol for the fail-safe position "Actuator stem extends" or "Actuator stem retracts" is aligned with the marking (Fig. 11, below).
  - ▶ Make sure that the gasket for the connecting plate (9) is correctly inserted.
  - ▶ The connecting plate has boreholes with NPT and G threads.
- Seal the threaded connection that is not used with the rubber seal and square plug.

**Type 3277 Actuator with 240 to 700 cm<sup>2</sup>:**

The signal pressure is routed to the connection at the side of the actuator yoke for the version "Actuator stem extends".

For the fail-safe position "Actuator stem retracts" the connection on the top diaphragm case is used. The connection at the side of the yoke must be fitted with a venting plug (accessories).

**Mounting the position sensor**

1. Place the lever (1) on the sensor in mid-position and hold it in place. Unthread the nut (1.1) and remove the lever together with the disk spring (1.2) from the sensor shaft.

2. Screw the position sensor (20) onto the mounting plate (21).
3. Depending on the actuator size and rated travel of the valve, determine the required lever and position of the follower pin (2) from the travel table on page 13.

The positioner is delivered with lever **M** in pin position **35** on the sensor. If necessary, remove the follower pin (2) from its pin position and move it to the borehole for the recommended pin position and screw tight.

4. Place the lever (1) and disk spring (1.2) on the sensor shaft.

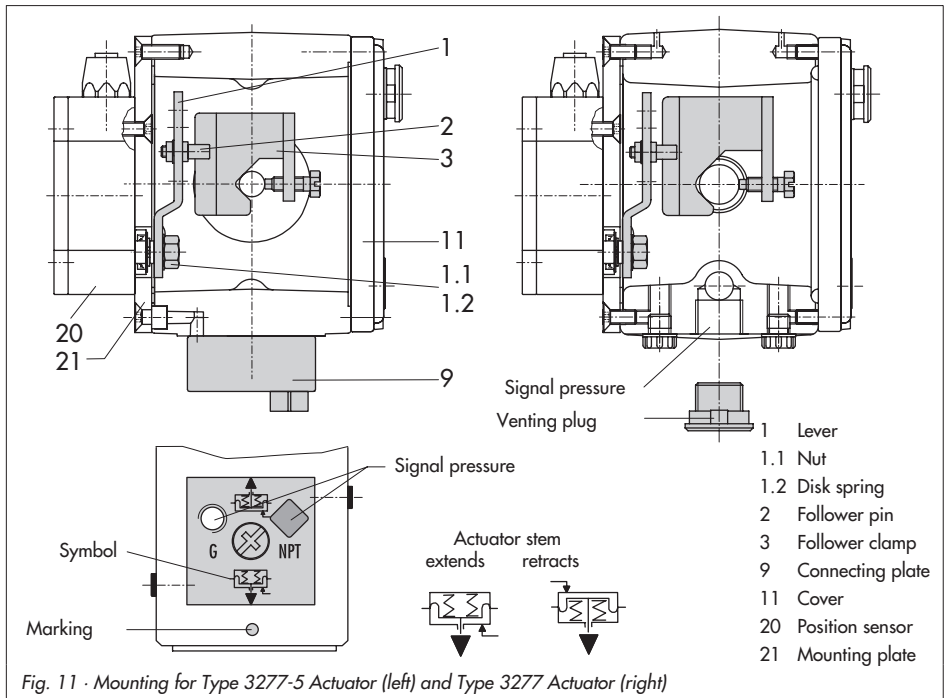

Place the lever (1) in **mid-position** and **hold it in place**. Screw on the nut (1.1).

5. Place the follower clamp (3) on the actuator stem, align and fasten it, making sure that the fastening screw rests in the groove of the actuator stem.
6. Place the mounting plate (21) together with the sensor onto the actuator yoke so that the follower pin (2) rests on the top of the follower clamp (3). It must rest on it with spring force. Screw tight the mounting plate (21) onto the actuator yoke using both fixing screws.
7. Mount cover (11) on the other side. Make sure that the vent plug points downwards when the control valve is installed to allow any condensed water that collects to drain off.

## 2.6.2 Mounting the position sensor with attachment according to IEC 60534-6

For the required mounting parts as well as the accessories, refer to the order numbers listed in Tables 6 and 7 on page 33.

1. Place the lever (1) on the sensor in **mid-position** and **hold it in place**. Unthread the nut (1.1) and remove the lever together with the disk spring (1.2) from the sensor shaft.
2. Screw the position sensor (20) onto the bracket (21).

The standard attached lever **M** with the follower pin (2) at position **35** is designed for 120, 240 and 350 cm<sup>2</sup> actuators with 15 mm rated travel.

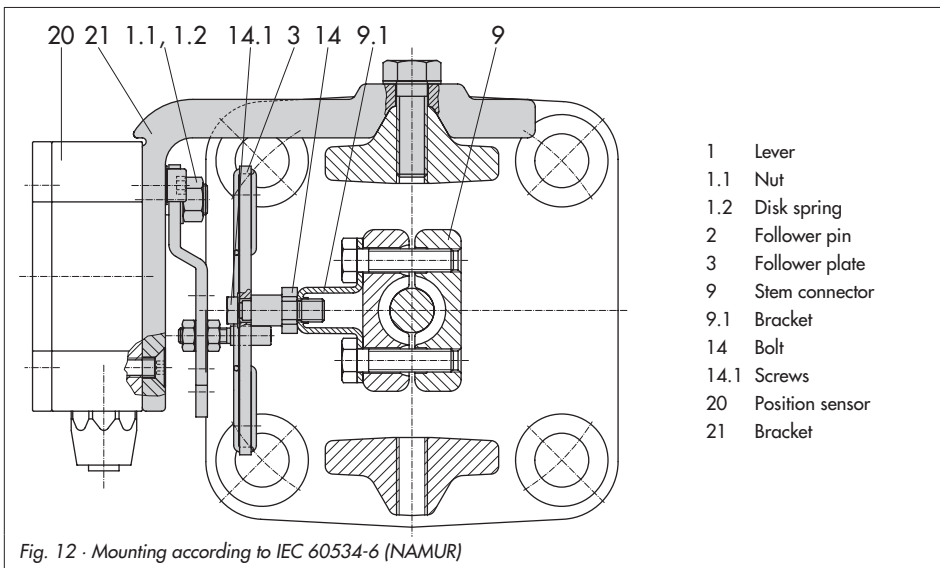

- |      |                 |
|------|-----------------|
| 1    | Lever           |
| 1.1  | Nut             |
| 1.2  | Disk spring     |
| 2    | Follower pin    |
| 3    | Follower plate  |
| 9    | Stem connector  |
| 9.1  | Bracket         |
| 14   | Bolt            |
| 14.1 | Screws          |
| 20   | Position sensor |
| 21   | Bracket         |

For other actuator sizes or travels, select the lever and pin position from the travel table on page 13. Lever **L** and **XL** are included in the mounting kit.

- Place the lever (1) and disk spring (1.2) on the sensor shaft.  
Place the lever (1) **in mid-position** and **hold it in place**. Screw on the nut (1.1).
- Screw both bolts (14) to the bracket (9.1) of the stem connector (9). Attach the follower plate (3) and fix with the screws (14.1).
- Place the bracket with the sensor at the NAMUR rib in such a manner that the follower pin (2) rests in the slot of the follower plate (3), then screw the bracket using its fixing screws onto the valve.

### 2.6.3 Mounting the position sensor to Type 3510 Micro-flow Valve

For the required mounting parts as well as the accessories, refer to the order numbers listed in Tables 6 and 7 on page 33.

- Place the lever (1) **in mid-position** and **hold it in place**. Unscrew the nut (1.1) and remove the standard attached lever **M** (1) together with the disk spring (1.2) from the sensor shaft.
- Screw the position sensor (20) onto the bracket (21).
- Select the lever **S** (1) from the accessories and screw the follower pin (2) into the hole for pin position **17**.  
Place the lever (1) and disk spring (1.2) on the sensor shaft.

- Place the lever (1) in mid-position and hold it in place. Screw on the nut (1.1).
- Place the follower clamp (3) on the stem connector, align it at a right angle and screw tight.
- Position the bracket (21) with the position sensor on the valve yoke and screw tight, making sure the follower pin (2) slides into the groove of the follower clamp (3).

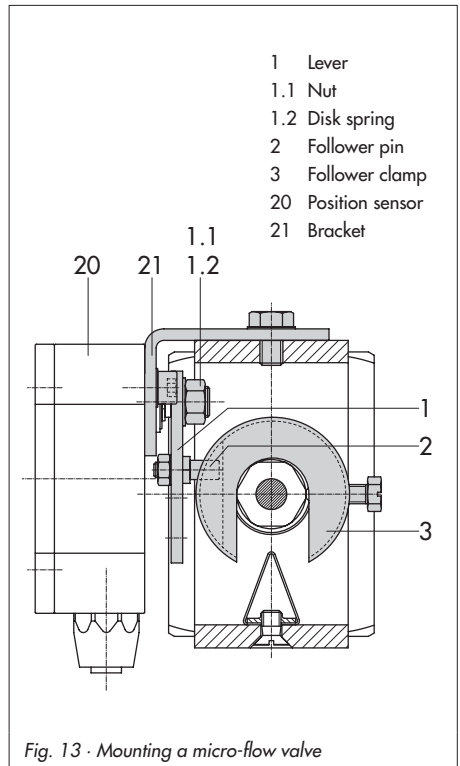

Fig. 13 · Mounting a micro-flow valve

## 2.6.4 Mounting the position sensor to rotary actuators

For the required mounting parts as well as the accessories, refer to the order numbers listed in Tables 6 and 7 on page 33.

1. Place the lever (1) **in mid-position** and **hold it in place**. Unscrew the nut (1.1) and remove the standard attached lever **M** (1) together with the disk spring (1.2) from the sensor shaft.
2. Screw the position sensor (20) onto the bracket (21).
3. Replace the follower pin (2) normally attached to the lever (1) with the metal follower pin ( $\varnothing 5$ ) from the accessories and screw it into the hole for pin position  $90^\circ$ .

4. Place the lever (1) and disk spring (1.2) on the sensor shaft.  
Place the lever (1) **in mid-position** and **hold it in place**. Screw on the nut (1.1).

Follow the instructions describing attachment to the standard positioner in section 2.4. Instead of the positioner, attach the position sensor (20) with its mounting plate (21).

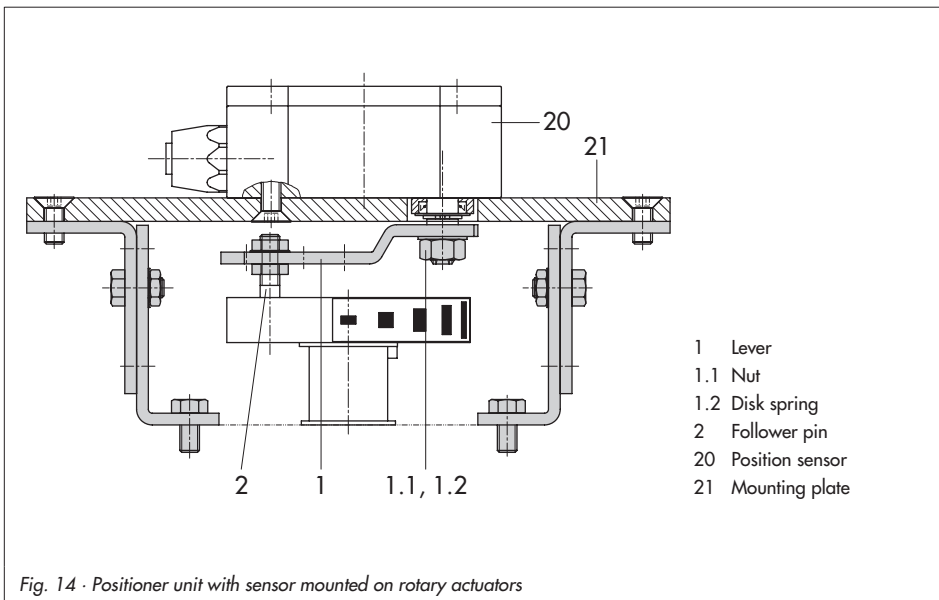

- 1 Lever
- 1.1 Nut
- 1.2 Disk spring
- 2 Follower pin
- 20 Position sensor
- 21 Mounting plate



Table 6		Mounting parts for position sensor	Order no.
Direct attachment	Mounting parts for actuators with 120 cm <sup>2</sup> see Fig. 11 left		1400-7472
Accessories for actuator 120 cm <sup>2</sup>	Connecting plate (9, old) for Actuator Type 3277-5xxxxx.00	G 1/8 1/8 NPT	1400-6820 1400-6821
	Connecting plate (new) for Actuator Type 3277-5xxxxx.01 (new)		1400-6823
	<b>Note:</b> Only new switchover and connecting plates can be used with new actuators (Index 01). Old and new plates are not interchangeable.		
Direct attachment	Mounting parts for actuators with 240, 350 and 700 cm <sup>2</sup> , see Fig. 11 right		1400-7471
NAMUR attachment	Mounting parts for attachment to NAMUR rib w. lever L and XL, see Fig. 12		1400-7468
Attachment to micro-flow valves	Mounting parts for Type 3510 Micro-flow Valve, see Fig. 13		1400-7469
Attachment to rotary actuators	Mounting parts with follower clamp and coupling wheel, see Fig. 14		1400-7473
Table 7		Positioner accessories	Order no.
Accessories	Connecting plate (6)	G 1/4 1/4 NPT	1400-7461 1400-7462
	or pressure gauge bracket (7)	G 1/4 1/4 NPT	1400-7458 1400-7459
	Pressure gauge mounting kit (8) (output and supply)	St. steel/Brass St.st./St. steel	1400-6950 1400-6951

## 3 Connections

### 3.1 Pneumatic connections

#### **Caution!**

*The threads in the positioner housing are not designed for direct air connection!*

The screw glands must be screwed into the connecting plate, the pressure gauge mounting block or the connection block from the accessories. The air connections are optionally designed as a bore with 1/4 NPT or G 1/4 thread.

The customary fittings for metal and copper pipes or plastic hoses can be used.

#### **Note!**

*The supply air must be dry and free from oil and dust. The maintenance instructions for upstream pressure reducing stations must be observed.*

*Blow through all air tubes and hoses thoroughly prior to connecting them.*

If the positioner is attached directly to the Type 3277 Actuator, the connection of the positioner's output pressure to the actuator is fixed. For attachment according to IEC 60534-6 (NAMUR), the signal pressure can be routed to either the top or bottom diaphragm chamber of the actuator, depending on the actuator's fail-safe action "Actuator stem extends" or "Actuator stem retracts".

For rotary actuators, the manufacturer's specifications for connection apply.

### 3.1.1 Signal pressure gauges

To monitor the supply air (Supply) and signal pressure (Output), we recommend that pressure gauges be attached (see accessories in Tables 1 to 5).

### 3.1.2 Supply pressure

The required supply air pressure depends on the bench range and the actuator's operating direction (fail-safe action).

The bench range is registered on the nameplate either as spring range or signal pressure range depending on the actuator. The direction of action is marked **FA** or **FE**, or by a symbol.

#### **Actuator stem extends FA (Air to open ATO)**

Fail-safe position "Valve Closed"  
(for globe and angle valves):

Required supply pressure = Upper bench range value + 0.2 bar, minimum 1.4 bar.

#### **Actuator stem retracts FE (Air to close ATC)**

Fail-safe position "Valve Open"  
(for globe and angle valves):

For tight-closing valves, the maximum signal pressure  $p_{st_{max}}$  is roughly estimated as follows:

$$p_{st_{max}} = F + \frac{d^2 \cdot \pi \cdot \Delta p}{4 \cdot A}$$

$d$  = Seat diameter [cm]

$\Delta p$  = Differential pressure across the valve  
[bar]

$A$  = Actuator diaphragm area [cm<sup>2</sup>]

$F$  = Upper bench range of the actuator  
[bar]

**If there are no specifications, calculate as follows:**

Required supply pressure =  
Upper bench range value + 1 bar

---

**Note!**

*The signal pressure at the output (Output 38) of the positioner can be limited to 1.4, 2.4 or 3.7 bar over Code 16 or the pressure limit can be deactivated (MAX).*

---

## 3.2 Electrical connections



For electrical installation, you are required to observe the relevant electrotechnical regulations and the accident prevention regulations that apply in the country of use. In Germany, these are the VDE regulations and the accident prevention regulations of the employers' liability insurance association.

The following standards apply for installation in hazardous areas:

EN 60079-14: 2003 (VDE 0165 Part 1) "**Electrical apparatus for explosive gas atmospheres**" and EN 50281-1-2: 1999 (VDE 0165 Part 2) "**Electrical apparatus for use in the presence of combustible dust**".

For the interconnection of intrinsically safe electrical equipment, the permissible maximum values specified in the EC type examination certificate apply ( $U_i$  or  $U_{0i}$ ;  $I_i$  or  $I_{0i}$ ;  $P_i$  or  $P_{0i}$ ;  $C_i$  or  $C_{0i}$ , and  $L_i$  or  $L_{0i}$ ).

For EEx nA equipment (non-sparking apparatus), the standard EN 50021: 1999 specifies that connecting, interrupting, or switching circuits while energized is only allowed during installation, maintenance or repair work.

For EEx nL equipment (energy-limited apparatus), the standard EN 50021: 1999 allows this type of equipment to be switched under normal operating conditions.

---

**Caution!** The terminal assignment specified in the certificate must be adhered to. Reversing the assignment of the electrical terminals may cause the explosion protection to become ineffective!

Do not tamper with enameled screws inside or on the housing.

**Note on the selection of cables and wires:**

To install intrinsically safe circuits, observe section 12 of the standard EN 60079-14: 2003 (VDE 0165 Part 1). To run multi-core cables or lines with more than one intrinsically safe circuit, section 12.2.2.7 of this standard applies.

An additional cable gland can be installed when connecting the device over two separate cables. Cable entries left unused must be sealed with blanking plugs. Devices used at ambient temperatures down to  $-40\text{ }^{\circ}\text{C}$  must have metal cable entries.

---

The wires for the reference variable must be connected to the terminals 11 and 12 located in the housing. Only use a **current source!**

---

**Caution!** The erroneous connection of a voltage source of just around 7 V (or around 2 V when connected to the wrong pole) can damage the positioner.

---

In general, it is not necessary to connect the positioner to a bonding conductor. Should this be required, however, this conductor can be connected inside the device.

Depending on the version, the positioner is equipped with inductive limit switches and/or a solenoid valve.

The position transmitter is operated on a two-wire circuit. The usual supply voltage is 24 V DC. Considering the resistance of the supply leads, the voltage at the position transmitter terminals can be between 12 and 30 V DC.

Refer to Fig. 15 or the label on the terminal strip for terminal assignment.

**Note!** The minimum permissible reference variable should not fall below 3.8 mA for operating the positioner.

**Accessories:**

- Plastic cable gland M20 x 1.5:
- Black Order no. 1400-6985
- Blue Order no. 1400-6986
- Nickel-plated brass Order no. 1890-4875
- Adapter M20 x 1.5 to 1/2 NPT
- Aluminum, powder-coated Order no. 0310-2149

**Connection for version with external position sensor**

The terminal assignment is fixed by the connector of the connecting lead.

- ▶ Shorten the connecting lead to the required length and strip the insulation off. Route the strands to the following contacts of the free connector:

Contact	Cable color
1	Brown
2	White
3	Blue
4	Black shielding
5	Green/yellow

- ▶ Connect the fixed M12x1 plug connector to the position sensor and the mounted connector to the positioner unit.

**3.2.1 Switching amplifiers**

For operation of the limit switches, switching amplifiers must be connected in the output circuit. To ensure the operating reliability of the positioner, the amplifiers should comply with the limit values of the output circuits conforming to EN 60947-5-6. If the positioner is to be installed in hazardous areas, the relevant regulations must be observed.

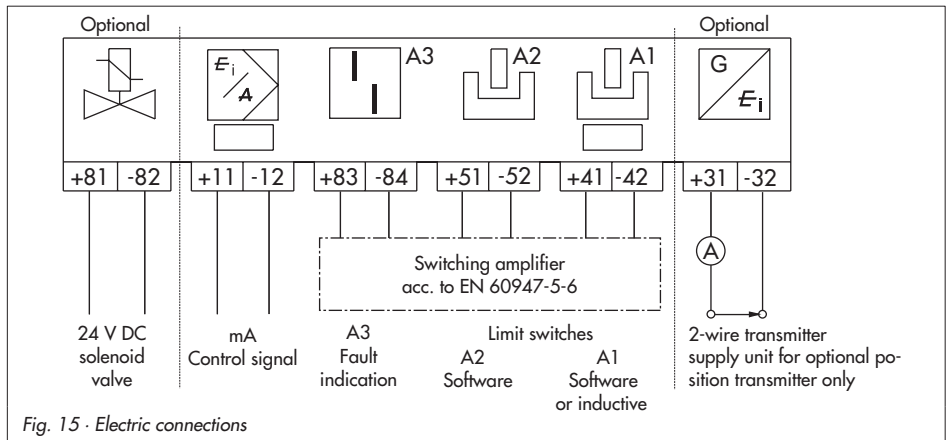

Fig. 15 · Electric connections

### 3.2.2 Establishing communication

Communication between PC and positioner (via FSK modem or handheld communicator, if necessary, using an isolation amplifier) is based on the HART protocol.

Type Viator FSK modem

RS 232 EExia Order no. 8812-0129

RS 232 not ex Order no. 8812-0130

PCMCIA not ex Order no. 8812-0131

USB not ex Order no. 8812-0132

If the supply voltage of the controller or control station becomes too low because it has been reduced by the load in the circuit, an isolation amplifier is to be connected be-

tween controller and positioner (interfacing as for positioner connected in hazardous areas, see Fig. 16).

If the positioner is used in hazardous areas, an explosion-protected isolation amplifier is to be used.

By means of the HART protocol, all control room and field devices connected in the loop are individually accessible through their address via point-to-point or standard bus (Multidrop).

#### Point-to-point:

The bus address/polling address must always be set to zero (0).

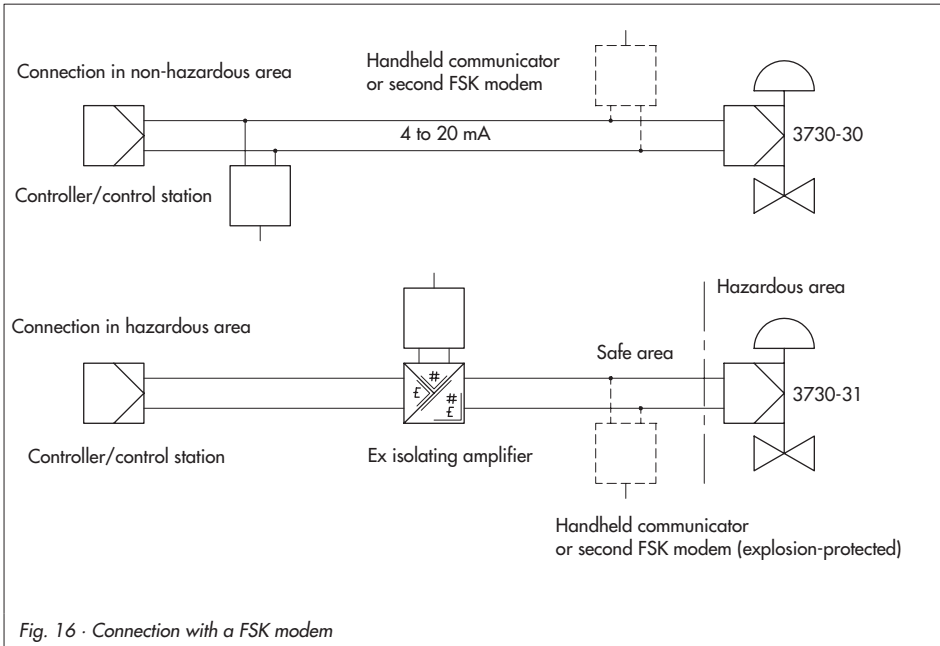

Fig. 16 · Connection with a FSK modem

### Standard bus (Multidrop):

In the standard bus (Multidrop) mode, the positioner follows the analog current signal (reference variable) as for point-to-point communication. This operating mode is, for example, suitable for split-range operation of positioners (series connection). The bus address/polling address has to be within a range of 1 to 15.

### Note:

Communication faults may occur when the process controller/control station output is not HART-compatible.

For adaptation, the Z box (order no. 1170-2374) can be installed between output and communication interface.

At the Z box a voltage of 330 mV is released ( $16.5 \Omega$  at 20 mA).

Alternatively, a  $250\text{-}\Omega$  resistor can be connected in series and a  $22\text{-}\mu\text{F}$  capacitor can be connected in parallel to the analog output. Note that in this case, the controller output load will increase.

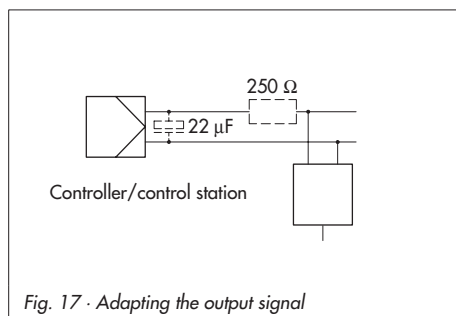

Fig. 17 · Adapting the output signal

## 4 Operation

### Note!

A summary about operating and start up can be found in section 7 on page 60. A leaflet including the same summary is also enclosed with the positioner.

### 4.1 Operator controls and display

#### Rotary pushbutton

The positioner is mainly operated with the rotary pushbutton.

Turn the  button to select and set codes, parameter and values. Press it to confirm them.

#### Slide switch AIR TO OPEN or AIR TO CLOSE

This switch is used to adapt the positioner to the operating direction of the actuator.

For actuator where the supply pressure opens the valve, fail-safe position: "springs close valve": switch position AIR TO OPEN.

For actuator where the supply pressure closes the valve, fail-safe position: "springs open valve": switch position AIR TO CLOSE.

For positioners with an attached reversing amplifier for double-acting rotary actuators (section 2.5): switch position AIR TO OPEN.

The switch position is prompted prior to an initialization. After an initialization has been completed, changing the switch position does not have any effect on the operation of the positioner.



#### Volume restriction Q

The volume restriction is used to adapt the air delivery to the actuator size. Two fixed settings are possible depending on how the air is routed at the actuator:

- ▶ For actuators smaller than 240 cm<sup>2</sup> with a loading pressure connection at the side (Type 3271-5), set restriction to MIN SIDE.
- ▶ For a connection at the back (Type 3277-5), set restriction to MIN BACK.
- ▶ For actuators 240 cm<sup>2</sup> and larger, set to MAX SIDE for a side connection and to MAX BACK for a connection at the back.

#### Displays

The LC display indicates symbols that are assigned to parameters, codes and functions.

The bar graph in the operating modes Manual  and Automatic  indicates the system deviation that depends on the sign (+/-) and the value. One bar graph element appears per 1 % system deviation.

If the device has not yet been initialized (see section 4.3.1), the lever position in degrees in relation to the longitudinal axis is indicated instead of the system deviation. One bar graph element corresponds to approximately a 5° angle of rotation.

If the fifth element blinks (value displayed > 30°), the permissible angle of rotation has been exceeded. Lever and pin position must be checked.



Displays and their meaning

<b>AUTO</b>	Automatic mode	<b>MAX</b>	Maximum range	<b>TUN E</b>	Initialization in progress
<b>CL</b>	Clockwise	<b>NO</b>	Not available	<b>YES</b>	Available
<b>CCL</b>	Counterclockwise	<b>NOM</b>	Nominal travel	<b>ZP</b>	Zero calibration
<b>Err</b>	Error	<b>ON</b>	ON		
<b>ESC</b>	Escape	<b>OFF</b>	OFF	↗↗	Increasing/increasing
<b>HI</b>	ix greater than 21.6 mA	<b>RES</b>	Reset	↘↘	Increasing/decreasing
<b>LO</b>	ix smaller than 2.4 mA	<b>RUN</b>	Start	↻	Blinking Controlled operation
<b>LOW</b>	w too low	<b>SAFE</b>	Fail-safe position	↻	Blinking Not initialized
<b>MAN</b>	Manual mode	<b>Sub</b>	Substitute calibration		

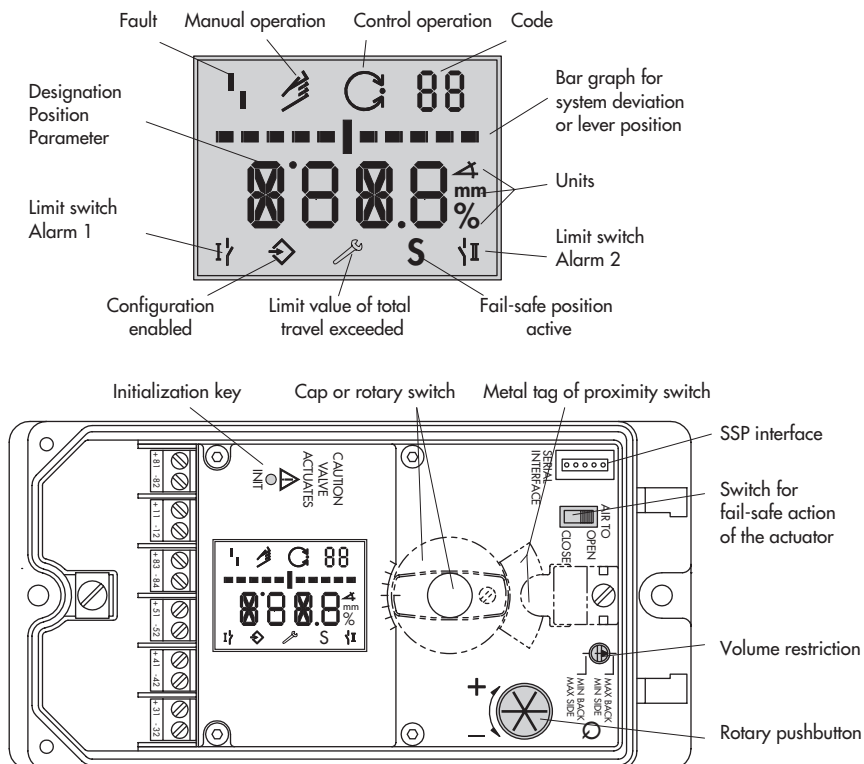

Fig. 18 · Display and operator controls

## 4.2 Enabling and selecting parameters

The codes which are marked with an asterisk (\*) in section 11 on page 65 onwards must be enabled with Code 3 before the associated parameters can be configured as described below.



Code 3  
Configuration  
not enabled



Configuration  
enabled

- ▶ From the current display, turn the rotary pushbutton until Code 3 and OFF appear on the display. Confirm Code 3 by pressing the button, the code number blinks.
- ▶ Turn button until ON appears. Confirm setting by pressing the button.

Configuration is enabled and is indicated by symbol appearing on the display.

Now you can adjust the codes, parameters and values for the control valve in any desired order by turning the button. Confirm settings by pressing the button.

### Note!

To cancel a value that you have just entered under a code, turn the button until **ESC** appears on the display and press to confirm.



Canceling the setting

**Note!** If no settings are entered within 120 seconds, the enabled configuration function becomes invalid and the display resets to Code 0.

The code list on page 65 onwards in section 11 shows all parameters that can be adjusted, including their description and their default settings.

### Important!

After attaching the positioner to the valve as well as setting the fail-safe position and the volume restriction, it is sufficient for standard operation to press the initialization key in order to ensure optimum positioner operation (section 5.5 on page 47).

For this purpose, the positioner must be operated with its default values. If necessary, a reset must be carried out (section 5.10 on page 57).

## 4.3 Operating modes

### 4.3.1 Automatic and manual operating modes

#### Prior to initialization:

If the positioner has not been initialized yet, the automatic operating **AUTO** cannot be selected.

The valve can only be positioned manually with the positioner.

To proceed, turn  button clockwise until Code **1** appears, then confirm Code **1** by pressing the  button.



If both the code number and the hand symbol are blinking, the valve can be manually positioned by turning the  button.

This type of manual adjustment is used to check the operating range of the positioner, see also section 5.4 on page 45.

#### After initialization:

After successful initialization in the **MAX**, **NOM** or **MAN** mode (section 5.5.1), the positioner is in the automatic control operation mode .

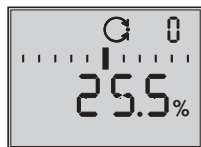

Standard

#### Switching to manual operating mode

Over Code **0**, press the  button, **AUTO** appears in the display, Code **0** blinks.



Turn  button until **MAN** appears.



Press  button to confirm, the hand symbol appears and then the current position in %.

Turn  button until Code **1** appears.



Press  button to confirm, Code **1** blinks. The positioner is in the manual operating mode .

The switchover is smooth since the manual operating mode starts up with the set point last used during automatic operating mode.

The required valve position can be adjusted by turning the  button.

#### Note!

Switching from manual to automatic operating mode works in the same manner.

First, you must reset the positioner to Code **0** and set it to automatic mode **AUTO** and confirm.

### 4.3.2 SAFE – Fail-safe position

If you want to move the valve to fail-safe position, proceed as follows:

Select Code **0**, press the  button, **AUTO** or **MAN** appears on the display, Code **0** blinks.

Turn the  button until **SAFE** appears.



Press the  button to confirm this setting.

Operating mode **SAFE** has been selected, symbol **S** for the fail-safe position appears.

#### Caution!

The valve moves to the fail-safe position.

Once the positioner is initialized, the current valve position is indicated on the digital display in %.

If you want to return the valve from the fail-safe position to the operating mode **AUTO** or **MAN**, the  button must be pressed while Code **0** is active.

When the code number blinks, turn the  button to switch to the desired operating mode.

Press the  button to confirm.

## 5 Start-up and settings

### Note!

A summary about start-up and operation can be found in section 7 on page 60. A leaflet including the same summary is also enclosed with the positioner.

- ▶ Connect pneumatic supply air (Supply 9), making sure the pressure is correct as described in section 3.1.
- ▶ Apply an electrical reference variable of 4 to 20 mA (terminals 11 and 12).
- ▶ The voltage supply >19 V DC for version with a solenoid valve must be connected at terminals 81 (+) und 82 (-).



### Warning!

The signal pressure supplied may cause the actuator stem to move, be aware of risk of injury!

### 5.1 Determining the fail-safe position

To adapt the positioner to the operating direction of the actuator, set slide switch to AIR TO OPEN or AIR TO CLOSE .

AIR TO OPEN = Signal pressure opens the valve, for fail-safe position: actuator stem extends/valve closed

AIR TO CLOSE = Signal pressure closes the valve, for fail-safe position: actuator stem retracts/valve open.

The switch position is prompted prior to an initialization. After an initialization has been completed, changing the switch position

does not have any effect on the operation of the positioner.

## 5.2 Setting the volume restriction Q

- ▶ For actuators smaller than 240 cm<sup>2</sup> with a loading pressure connection at the side (Type 3271-5), set restriction to MIN SIDE.
- ▶ For a connection at the back (Type 3277-5), set restriction to MIN BACK.
- ▶ For actuators 240 cm<sup>2</sup> and larger, set to MAX SIDE for a side connection and to MAX BACK for a connection at the back.

**Note!** The positioner must re-initialized if the volume restriction setting is changed after the positioner has already been initialized.

### Adapting the display



The data representation on the positioner display can be turned by 180°. If the displayed data appear upside down, proceed as follows:





Reading direction for right attachment of pneumatic connections



Reading direction for left attachment of pneumatic connections

Turn the  button until Code **2** appears, and press the  button to confirm Code **2**, Code **2** blinks.

- ▶ Turn  button until the display is adjusted to the desired direction, then confirm reading direction by pressing the  button.

## 5.3 Limiting the signal pressure

If the maximum actuator force may cause damage to the valve, the signal pressure must be limited. Select Code **3** to enable configuration and then access Code **16** to set the pressure limit to 1.4, 2.4 or 3.7 bar.

## 5.4 Checking the operating range of the positioner





To check the mechanical attachment and the proper functioning, the valve should be moved through the operating range of the positioner in the manual operating mode with the manual reference variable.

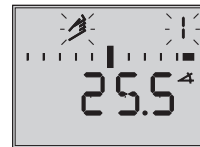



Code 0  
Select manual operation  
Default **MAN**



Code 1  
Position valve using the rotary pushbutton, the current angle of rotation is indicated

1. Turn the  button until Code **0** appears, then confirm Code **0** by pressing the  button.
2. Turn the  button until **MAN** appears in the display, i.e. manual operating mode, confirm selected operating mode by pressing the  button.

3. Turn the  button until Code **7** appears, confirm Code **7** by pressing  button. The hand symbol and Code **7** blink.
4. Position control valve by turning the  button several times until pressure builds up, and the control valve moves to its final positions so that the travel/angle of rotation can be checked.  
The permissible range has been exceeded when the displayed angle is higher than 30°, and the outer right or left bar graph element blinks.  
If this is the case, it is absolutely necessary to check lever and pin position as described in section 2.

---

### **Note!**

*If the selected pin position is smaller than intended for the respective travel range, the positioner switches to the **SAFE** mode, the valve moves to the fail-safe position (see section 4.3.25.1 on page 44).*

---

5. Initialize positioner as described in section 5.5.

### **Simplified start-up!**

*For most applications, the positioner with its default settings is ready for operation, provided it has been properly attached.*

*After the fail-safe position and the volume restriction have been set, the positioner only needs to be initialized by pressing the INIT key.*

### **Caution!**

*Prior to starting the initialization procedure, check the maximum permissible supply pressure of the control valve to prevent the valve from being damaged. On initialization, the positioner supplies the maximum available supply pressure. If necessary, restrict the signal pressure by using a pressure reducing valve upstream of the control valve.*

*Initialization is run in default mode **MAX** (section 5.5.1). During this process, the positioner adapts itself optimally to the maximum travel/angle of rotation range. The only parameter that must be checked is the direction of action, i.e. whether the default setting (Code **7** to **77** = increasing/increasing) matches the application or whether it must be changed.*

*The initialization modes described in following serve to individually adapt and optimize the positioner to the way it is attached to the valve.*

## 5.5 Initialization

During initialization the positioner adapts itself optimally to the friction conditions and the signal pressure demand of the control valve.

The type and extent of self-adaptation depends on the set initialization mode (see section 5.5.1).

**MAX** is the default setting for initialization based on the maximum nominal range.

If configuration is enabled via Code **3**, Code **6** can be used to change to other initialization modes.

If the positioner has been initialized once already, it will automatically go to the operating mode used last after the electrical reference variable is applied, Code **0** appears on the display.

On initializing the positioner for the first time, the hand symbol appears on the display.

### Note!

Every time you re-initialize the positioner, it should be reset to its basic setting including the default values. Refer to section 5.10 on page 57.

- ▶ The initialization process can be started by pressing the INIT key with a suitable tool.

### Note!

The time required for the initialization procedure depends on the running time of the actuator and can take a few minutes.



### Warning!

During the initialization, the control valve moves through its entire travel/angle of rotation range. Therefore, do not start initialization while a process is running, but only during start-up, when all shut-off valves are closed.

### Note!

The initialization procedure can be interrupted while running by pressing **STOP** appears three seconds long and the positioner then moves to the fail-safe position.



Alternating displays  
Initialization running



Bar graph display  
indicating the progress of  
the initialization



Initialization successful,  
positioner in automatic  
operating mode

After a successful initialization, the positioner runs in control operation indicated by the control symbol.

The control position in % predetermined by the reference variable appears on the display.

A malfunctioning leads to the process being interrupted. The  $\text{I}_1$  fault symbol appears on the display. See section 5.8 on page 56. If the slide switch is set to AIR TO CLOSE, the positioner with firmware version 1.10 or higher automatically switches to the direction of action increasing/decreasing ( $\nearrow\searrow$ ) on successful completion of initialization. This results in the following assignment between reference variable and valve position:

Fail-safe position	Direction of action	Valve	
		Closed at	Open at
Actuator stem extends FA AIR TO OPEN	$\nearrow\nearrow$	4 mA	20 mA
Actuator stem retracts FE AIR TO CLOSE	$\nearrow\searrow$	20 mA	4 mA

The tight-closing function is activated. Set Code **15** (final position  $w>$ ) to 99 % for three-way valves. Further settings relevant for the valve can be entered subsequently.

### 5.5.1 Initialization modes

After enabling configuration with Code **3** and accessing Code **6**, you can choose one of the initialization modes **MAX**, **NOM**, **MAN** or **SUB** to start initialization. **ZP**, the zero calibration is described in section 5.9 on page 56.

#### MAX – Initialization based on maximum range

Initialization mode for simplified start-up.

The positioner determines travel/angle of rotation of the closing member from the CLOSED position to the opposite side and

adopts this travel/angle of rotation as the operating range from 0 to 100 %.

For control valves, whose maximum range exceeds the effective travel/angle of rotation range (nominal range), you should reduce the operating range (maximum range) subsequently to the required nominal range (with Code **9** = upper x-range value) to reach optimum control results.

Enable configuration:



Default **OFF**

Turn  $\otimes$  → Code **3**, press  $\otimes$ ,

Turn  $\otimes$  → ON, press  $\otimes$ .

After enabling:



Default **MAX**

Turn  $\otimes$  → Code **6**, press  $\otimes$ ,

Turn  $\otimes$  → MAX, press  $\otimes$ .

▶ **Press INIT key to start initialization!**



*The initialization procedure may take several minutes, depending on the actuator size, as the valve moves through its entire travel/angle of rotation range.*



**Note!**



For **MAX** initialization, the positioner cannot indicate nominal travel/angle of rotation in mm/°, Code 5 remains disabled.

In addition, the lower (Code 8) and the upper (Code 9) x-range value can only be displayed and modified in %.

During **MAX** initialization, an increased system deviation (undefined final position of the actuator) in the upper control range may occur with some control valves due to the pneumatic actuator design.

If you want the display to indicate mm/°, proceed as follows after configuration has been enabled:

Turn  → Code 4, press ,

turn  → Select pin position entered during installation, press .

If you now switch to Code 5, the nominal range appears in mm/°.

The lower and upper x-range values for Code 8 and 9 are displayed in mm/° and can be adapted accordingly.

### **NOM – Initialization based on nominal range**

Initialization mode for globe valves, especially for valves with maximum ranges that are clearly greater than the required nominal range.

For this initialization mode, the following parameters must be entered: pin position (Code 4), nominal travel/angle (Code 5) and, if required, the direction of action (Code 7).

The calibrated sensor enables the effective valve travel to be preset very accurately.

During the initialization procedure, the positioner checks whether the control valve can move through the indicated nominal range (travel or angle) without collision. In case of a positive result, the indicated nominal range is adopted with the limits of lower x-range and upper x-range values as the operating range.

**Note!**

The maximum possible travel must always be greater than the nominal travel entered. If this is not the case, the initialization is interrupted (error indication Code 52) because the nominal travel is not achieved.

Enable configuration:



Default **OFF**

Turn  → Code 3, press ,

turn  → **ON**, press .

After enabling:

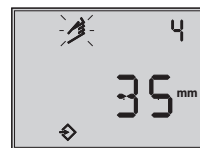

Default **OFF**

Turn  → Code 4, press ,

turn  → Select pin position entered during installation, press .



Default 15

Turn → Code 5, press ,  
turn → Enter nominal valve travel,  
press .

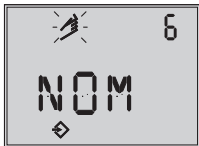

Default MAX

Turn → Code 6, press ,  
turn → **NOM**, press .

▶ **Press INIT key to start initialization!**



*The initialization procedure may take several minutes, depending on the actuator size, as the valve moves through its entire travel/angle of rotation range.*

**MAN – Initialization based on nominal range**

(with default upper x-range value by means of manual adjustment).

Initialization mode just as **NOM**, however, for starting up valves with unknown nominal range.

In this mode, the positioner expects the control valve to be moved manually to the desired OPEN position prior to enabling the initialization procedure.

The upper range travel/angle of rotation value is adjusted using the rotary pushbutton. The positioner uses this OPEN position and the CLOSED position to calculate the differential travel/angle and accepts it as the operating range with the lower x-range value and upper x-range value being the limits.

Enable configuration:





Default OFF

Turn → Code 3, press ,  
turn → **ON**, press .

After enabling:



Turn → Code 4, press ,  
turn → Select pin position entered during installation, press .



Turn  → Code **6**, press ,

turn  → **MAN**, press .



Default **MAX**

Turn , press ,

turn  → **MAN**, press .



Default **MAN**

Turn , press ,

Code **1** blinks.



Turn  until the valve reaches its **OPEN** position, press .

► **Press INIT key to start initialization!**



*The initialization procedure may take several minutes, depending on the actuator size, as the valve moves through its entire travel/angle of rotation range.*

## SUB

(substitute configuration, without initialization)

This initialization mode is an emergency mode. The positioner parameters are estimated and not determined by an initialization procedure, so that a high stationary accuracy cannot be expected.

You should always select a different initialization mode if the plant allows it.

The initialization mode **Sub** is used to replace a positioner while the process is in operation. For this purpose, the control valve is usually fixed mechanically in a certain position, or pneumatically by means of a pressure signal which is routed to the actuator externally. The blocking position ensures that the plant continues to operate with this valve position.

The spare positioner should not be initialized. If necessary, reset the spare positioner using Code **36**.

After the old positioner has been replaced with a new one, the following parameters must be entered: pin position (Code **4**), nominal range (Code **5**), direction of action (Code **7**) and closing direction (Code **34**). The default travel limit of 100 % (Code **11**) must be disabled with **OFF**.

In addition, the blocking position (Code **35**) must be adjusted with the  button so that it matches the position of the previously blocked valve.

The parameters  $K_P$  (Code **17**),  $T_V$  (Code **18**) and the pressure limit (Code **16**) should remain set to their default values. If the configuration data of the new positioner are

known, it is recommended to accept its  $K_p$  and  $T_v$  values.

After setting the AIR TO OPEN/CLOSE switch for the fail-safe position, setting the volume restriction and pressing the INIT key, the positioner calculates its configuration data on the basis of the blocking position and the closing direction as well as the other entered data.

The positioner switches to manual operation, subsequently the blocking position should be canceled as described on page 54.

Enable configuration:



Default **OFF**

Turn  $\otimes$  → Code **3**, press  $\otimes$ ,

turn  $\otimes$  → **ON**, press  $\otimes$ .

After enabling:



Default **OFF**

Turn  $\otimes$  → Code **4**, press  $\otimes$ ,

press  $\otimes$  → Select pin position entered during installation, press  $\otimes$ .



Default **15**

Turn  $\otimes$  → Code **5**, press  $\otimes$ ,

turn  $\otimes$  → Enter nominal travel/angle, press  $\otimes$ .



Default **MAX**

Turn  $\otimes$  → Code **6**, press  $\otimes$ ,

turn  $\otimes$  → **Sub**, press  $\otimes$ .



Default **↗**

Turn  $\otimes$  → Code **7**, press  $\otimes$ ,

turn  $\otimes$  → Retain direction of action **↗** or select **↘**.

Press  $\otimes$ .



Default **100.0**

Turn  $\otimes$  → Code **11**, press  $\otimes$ ,

turn  $\otimes$  → Deactivate travel limit, press  $\otimes$ .

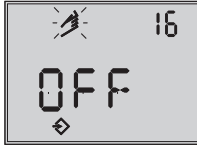

Default **OFF**

Turn → Code **16**,

Retain default value for pressure limit, change value only if necessary.

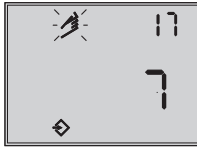

Default **7**

Turn → Code **17**

Retain default. Proceed as follows only if known:

Press ,

turn → Select Kp,

press .

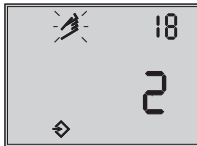

Default **2**

Turn → Code **18**,

Retain default Tv, change only if known.



Default **CCL**

Turn → Code **34**, press ,

turn → Select closing direction.

**CCL** = counterclockwise and **CL** = clockwise.

Direction of rotation which causes the valve to move to the CLOSED position (view onto the rotary switch movement while positioner cover is open).

Press .



Default **0.0**

Turn → Code **35**, press ,

turn → Enter blocking position, e.g. 5 mm (read off at travel indicator scale of the blocked valve or measure with a ruler).

Press .

▶ Set switch for **fail-safe position** AIR TO OPEN or AIR TO CLOSE as described in section 5.1 on page 44.

▶ Set volume restriction as described in section 5.2 on page 45.

▶ **Press INIT key!**

**The positioner switches to manual operation!**



The adjusted blocking position is indicated

As initialization has not been carried out completely, the error code **76** (no emer-

gency mode) and possibly also error code **57** may appear on the display.

These indications do not influence the positioner's readiness for operation.

### Canceling the blocking position

For the positioner to follow its reference variable again, the blocking position must be canceled and the positioner must be set to automatic operation **AUTO** as follows:

Press  $\otimes$  → Code **1**, press  $\otimes$ ,

turn  $\otimes$  in order to move the valve slightly past the blocking position, then cancel mechanical blocking.

Press  $\otimes$ .

Turn  $\otimes$  → Code **0**, press  $\otimes$ ,  
Code **0** blinks.

Turn  $\otimes$  until **AUTO** appears on the display.

Press  $\otimes$  to confirm the operating mode.

### The positioner switches to automatic operation!

The current valve position is indicated in %.

### Note!

*If the positioner shows a tendency to oscillate in automatic operating mode, the parameters  $K_P$  and  $T_V$  must be slightly corrected. Proceed as follows:*

*Set  $T_V$  to 4 (Code **18**).*

*If the positioner still oscillates, the gain  $K_P$  (Code **17**) must be decreased until the positioner shows a stable behavior.*

### Zero point correction

Finally, if process operations allow it, the zero point must be adjusted according to section 5.9 on page 56.

---

### Caution!

*The positioner automatically moves to zero point.*

---

## 5.6 Start-up via local interface (SSP)

The positioner must be supplied with at least 4 mA.

The positioner can be connected directly to the PC via the local serial interface and the serial interface adapter (Order no. 1400-7700).

Use the TROVIS-VIEW software with 3730-3 device module installed.

All device parameters can be accessed via the software.

For start-up and settings, proceed as described in section 5.

---

### **Note!**

*Depending on the firmware installed in the positioner, a certain minimum version of the TROVIS-VIEW device module is required for communication.*

*If you have already installed the software, you can download updates at [www.samson.de](http://www.samson.de) (Support & Downloads - TROVIS VIEW Updates).*

---

## 5.7 Start-up over HART communication

The positioner must be supplied with at least 4 mA current. The FSK modem must be connected in parallel to the current loop.

A DTM file (Device Type Manager) conforming to the Specification 1.2 is available for communication. This allows the device, for example, to be run with the PACTware operator interface. All the positioner's parameters are then accessible over DTM and the operator interface.

Proceed as described in section 5 for start-up and settings.

---

### **Note!**

*The write access for HART communication can be disabled over Code 47. You can only disable or enable this function locally at the positioner.*

*The write access is enabled by default. The on-site operation including the INIT key can be locked over HART communication. The word "HART" then blinks on the display when Code 3 is selected. This locking function can only be disabled over HART communication. On-site operation is enabled by default.*

---

## 5.8 Faults

In case of a fault, the fault symbol  appears at the top of the display in the left-hand corner.

Additionally, for some faults a signal is issued via the fault alarm contact (see error code list).

To access the error codes, turn the  button past the Code **50**.

**Err** appears on the display with the respective error code.

For the cause of the fault and its remedy, refer to the codes listed in section 11.

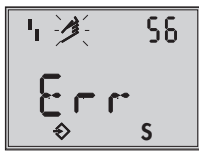

Display indicating an error code

After an error code has occurred, you should first try to confirm it as follows:

Enable configuration:

Turn  → Code **3**, press ,

turn  → **ON**, press .

Turn  until the error code number appears, then press  to confirm it.

Should the error occur again, read the remedy instructions in the error code list.

## 5.9 Zero calibration

In case of discrepancies with the closing position of the valve, e.g. with soft-sealed plugs, it may become necessary to recalibrate the zero point.

Enable configuration:



Default **OFF**

Turn  → Code **3**, press ,

turn  → **ON**, press .

After enabling:

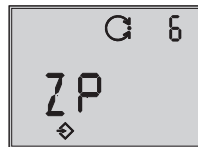

Default **MAX**

Turn  → Code **6**, press ,

turn  → **ZP**, press .

▶ **Press INIT key!**

Zero calibration is started, the positioner moves the control valve to the CLOSED position and readjusts the internal electrical zero point.



*The valve briefly moves from the current travel/angle of rotation position to the closed position.*



## 5.10 Reset to default values

This function resets all parameters to the factory default values (see list of codes in section 11).

Enable configuration:



Default *OFF*

Turn  → Code **3**, press ,

turn  → **ON**, press .

After enabling:



Default *OFF*

Turn  → Code **36**, press ,

turn  → **RUN**, press .

All parameters are reset and can be reconfigured.

### 6 Adjusting the limit switch

The positioner version with inductive limit switch has one adjustable tag (1) mounted on the shaft which operates the proximity switch (3).

For operation of the inductive limit switch, the corresponding switching amplifier (see section 3.2.1) must be connected to the output.

If the tag (1) is inside the field of the switch, the switch assumes a high resistance. If the tag is outside of the field, the switch assumes a low resistance.

Normally, the limit switch is adjusted such that it will provide a signal in both end positions of the valve. The switch, however, can also be adjusted to indicate intermediate valve positions.

The desired switching function, i.e. whether the output relay shall be picked up or released when the tag has entered the field, has to be determined, if necessary, at the switching amplifier.

---

#### **Note!**

*The inductive limit switch replaces the software limit switch A1 with terminal assignment +41/-42.*

*Each switching position can optionally be set to indicate when the tag has entered the field, or when it has left the field.*

*The second software limit switch remains effective, the function of the software limit switch A1 is disabled.*

---

#### **Software adaptation**

Code **38** (inductive alarm is set to **YES**).

The inductive limit switch is connected to the terminals +41/-42.

The device is set up accordingly when delivered ex works SAMSON.

#### **Setting the switching point:**

---

##### **Important!**

*During adjustment or testing, the switching point must always be approached from mid-position (50 %).*

---

To ensure safe switching under any ambient conditions, the switching point should be adjusted to a value of approx. 5 % before the mechanical stop (OPEN – CLOSED).

#### **For CLOSED position:**

1. Initialize positioner.
2. Use the **MAN** function to move the positioner to 5 % (see LC display).
3. Adjust the tag using the yellow adjustment screw (2) until the tag enters or leaves the field and the switching amplifier responds. You can measure the switching voltage as an indicator.

#### **Contact function:**

Tag leaving the field > contact is made.

Tag entering the field > contact is opened.

#### **For OPEN position:**

1. Initialize positioner.
2. Use the **MAN** function to move the positioner to 95 % (see LC display).
3. Adjust the tag (1) using the yellow adjustment screw (2) until the tag enters or

leaves the field of the proximity switch (3).

You can measure the switching voltage as an indicator.

### Contact function:

Tag leaving the field > Contact is made.

Tag entering the field > Contact is opened.

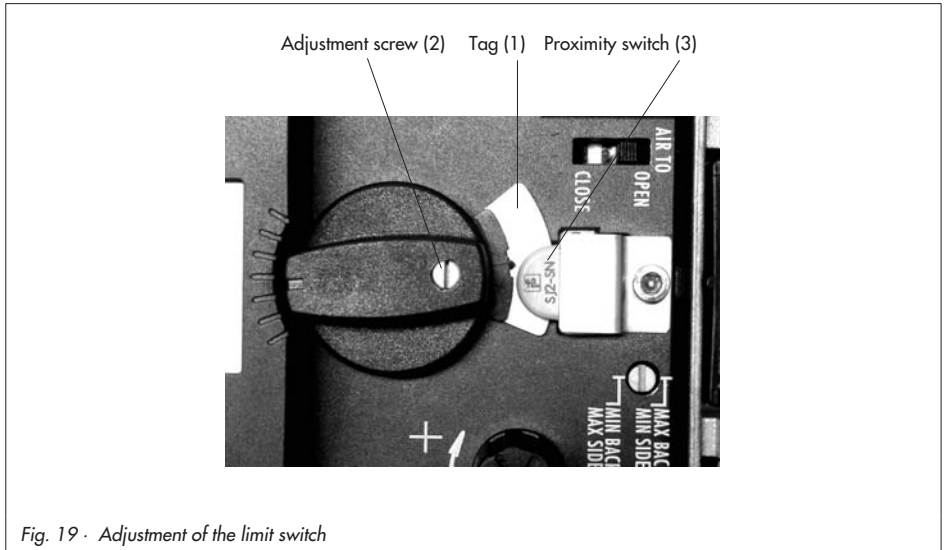

Fig. 19 · Adjustment of the limit switch

## 7 Quick start-up guide

### 7.1 Mounting

#### Direct attachment

to SAMSON Type 3277 Actuator

Travel mm	Actuator cm <sup>2</sup>	Pin position
7.5	120	25
15	120/240/350	35
15/30	700	50

#### Note!

*Standard delivery includes lever M ready assembled with the follower pin on 35 mm pin position for 15 mm travel!*

To mount the positioner, lift the lever so that the follower pin rests on the follower clamp of the actuator stem.

#### NAMUR attachment

- ▶ Determine the maximum travel range of the control valve from the closed position to as far it will go in the other direction.
- ▶ Select the lever to match the maximum travel range as well the next largest pin position and screw onto the shaft of the positioner.
- ▶ Lever option/pin distance: see table on page 67 or cover plate on the positioner.
- ▶ Screw the NAMUR bracket onto the valve yoke so that it is aligned centrally to the slot of the follower plate when the travel position is at 50 %.

- ▶ Secure the positioner to the NAMUR bracket, making sure that the follower pin is in the slot of the follower plate. Make sure the lever can still move.

#### Attachment to rotary actuators

- ▶ Lever M pin position 90°
- ▶ Put the valve into the closed position, determine the opening direction.
- ▶ Place the follower plate on the slotted actuator shaft and fasten it to the coupling wheel. Attach the top pair of brackets and the bottom pair of brackets to the actuator.
- ▶ Place the positioner on the brackets and screw tight, making sure that the lever with its follower pin engages the slot of the coupling wheel, while taking into account the opening direction.  
It is important to make sure that the lever's mid position corresponds to the mid travel of the valve (lever's mid position = the lever is parallel to the long side of the positioner casing).

#### Pneumatic connections

- ▶ Screw the threaded connections only into the attached connection block, connecting plate or pressure gauge block from the accessories.

## 7.2 Start-up

Connect pneumatic supply air (1.4 to 6 bar).

Apply an electrical reference variable (4 to 20 mA).

### Set the fail-safe position

Position the slide switch according to fail-safe position of the control valve:  
AIR TO OPEN or AIR TO CLOSE.

### Adapt the volume restriction Q to the actuator size

Only set the restriction for actuators < 240 cm<sup>2</sup> to:  
MIN SIDE for connection at the side or  
MIN BACK for connection at the back.

#### **Note!**

*After each change of the volume restriction setting, the positioner must be re-initialized.*

### Changing the reading direction of the display

(if necessary)

Turn  → Code 2, press ,

turn  → Display ok, press .

## Operation

### Selecting the parameters or values

Each parameter has a code number which is shown in the display. Use the  button to select.

**Turn** the button to select parameters or values and then **push** to confirm.

Select and confirm **ESC** to prevent an entered value from being accepted.

### Enabling parameters

Parameters that have a code marked with an asterisk (\*) can only be changed when they are enabled beforehand using Code 3.

The configuration mode is shown in the display with the  symbol.

See list of codes from page 65 onwards or cover plate of the positioner for a description of the menu codes.

## 7.3 Initialization

### **Important!**

Perform a reset (Code **36**) prior to each initialization

Turn  → Code **3**, ↵

turn  → ON, ↵

turn  → Code **36**, ↵

select **RUN**, ↵

### **Caution!**

During initialization, the valve runs through its whole range of travel/angle of rotation.

### 7.3.1 Simplest method (MAX)

Mount and start up the positioner and press the **INIT** key!

#### **READY!**

The positioner adapts itself automatically to the maximum travel/angle of rotation range of the control valve.

### 7.3.2 Precise method (NOM)

Positioner adapts itself precisely to the nominal travel/rotational angle of the control valve!

Mount and start up the positioner, then proceed as follows:

Turn  → Code **3**, ↵

turn  → ON, ↵

turn  → Code **4**, ↵

Select pin position, ↵

turn  → Code **5**, ↵

Enter nominal travel/range, ↵

turn  → Code **6**, ↵

select **NOM**, ↵

Press **INIT** key!

### 7.3.3 Manual method (MAN)

Initialization mode same as **NOM**, but for start-up of control valves with unknown nominal ranges. The final position of travel/angle of rotation (valve open) is entered manually.

Mount and start up the positioner, then proceed as follows:

Turn  → Code **0**, ↵,

turn  → select **MAN**, ↵

turn  → Code **1**, ↵,

turn  → valve **open** position, ↵

turn  → Code **3**, ↵,

turn  → **ON**, ↵

turn  → Code **6**, ↵, select **MAN**, ↵

Press **INIT** key!

### **Note!**

After imposing the electrical reference variable, the positioner is in the last used operating mode. Code **0** appears in the display. If the positioner has not yet been initialized, the  symbol blinks.

## 8 Retrofitting an inductive limit switch

### Required retrofit kit:

Limit switch Order no. 1400-7460

1. Take off the rotary pushbutton (3) and cap (1), unthread the five fixing screws (2) and lift off the plastic cover (9).
2. Use a knife to cut an opening at the marked location (4).
3. Push the connector (11) with cable through the opening and secure the proximity switch (7) on the cover with a dot of glue.
4. Remove the jumper at the socket ST1 of the top board and insert the cable connector (11).
5. Guide the cable in such a manner that the plastic cover can be placed back onto the positioner. Insert the fixing screws (2) and screw tight. Attach the clamping plate (8) onto the proximity switch.
6. Attach the rotary switch (5). Make sure the flattened side of the positioner shaft is turned so that the rotary switch (5) can be attached with the metal tag next to the proximity switch.
7. **Important!**

On start-up of the positioner, set the option "inductive alarm" under Code **38** from **NO** to **YES**.

- |                     |                    |
|---------------------|--------------------|
| 1 Cap               | 6 Metal tag        |
| 2 Screws            | 7 Proximity switch |
| 3 Rotary pushbutton | 8 Clamping plate   |
| 4 Marking           | 9 Plastic cover    |
| 5 Rotary switch     | 11 Connector       |

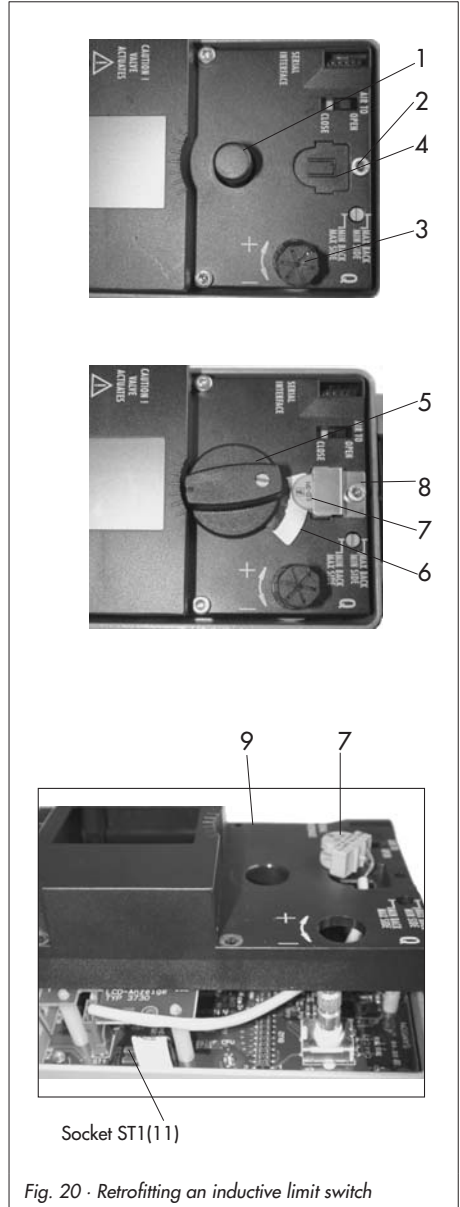

Fig. 20 · Retrofitting an inductive limit switch

## 9 Maintenance

The positioner does not require any maintenance.

There are filters with a 100 µm mesh size in the pneumatic connections for supply and output which can be removed and cleaned, if required.

The maintenance instructions of any upstream supply air pressure reducing stations must be observed.

## 10 Servicing explosion-protected devices

If a part of the positioner on which the explosion protection is based needs to be serviced, the positioner must not be put back into operation until an expert has inspected the device according to explosion protection requirements, has issued a certificate stating this or given the device a mark of conformity.

Inspection by an expert is not required if the manufacturer performs a routine check on the device prior to putting it back into operation. The passing of the routine check must be documented by attaching a mark of conformity to the device.

Devices that have already been used outside of hazardous areas and are intended for use in hazardous areas in future must comply with the safety demands placed on repaired devices. Prior to operation, they must be tested according to the specifications stipulated for "Repairing explosion-protected devices".



## 11 Code list

Code no.	Parameter – Display, values [default setting]	Description
<b>Important!</b> Codes with marked with an asterisk (*) must be enabled with Code 3 prior to configuration.		
<b>0</b>	<b>Operating mode</b> [MAN] AUtO SAFE ESC	AUtO = Automatic mode      MAN = Manual mode SAFE = Fail-safe position      ESC = Escape Switchover from automatic to manual mode is smooth. In fail-safe mode, the symbol <b>S</b> appears on the display. In MAN and AUtO mode, the system deviation is represented by the bar graph elements. When the positioner is initialized, the numerical display indicates the valve position or the angle of rotation in %, otherwise the position of the sensor in relation to the central axis is displayed in degrees °.
<b>1</b>	<b>Manual w</b> 0 to 100 [0] % of the nominal range	Adjust the manual set point with the rotary pushbutton, the current travel/angle is displayed in % when the positioner is initialized, otherwise the sensor position in relation to the central axis is indicated in degrees °.
<b>2</b>	<b>Reading direction</b> Normal or upside down ESC	The reading direction of the display is turned by 180°.
<b>3</b>	<b>Enable configuration</b> [OFF] ON ESC	Activates the option to modify data (automatically deactivated when the rotary pushbutton has not been operated for 120 s.) <b>HART</b> blinks on the display when the on-site operation is locked. Codes marked with an asterisk (*) can only be read and not overwritten. Likewise, codes can only read over the SSP interface.
<b>4*</b>	<b>Pin position</b> [OFF] 17, 25, 35, 50 mm 70, 100, 200 mm, 90° for rotary actuators ESC	The follower pin must be inserted into the correct pin position according to the valve travel/angle of rotation (select as per table on page 67, top). For initialization using NOM or SUB, this pin position must be entered.

5*	<b>Nominal range</b> [15.0] mm or angle ° ESC	For initialization using NOM or Sub, the nominal travel/angle of rotation of the valve must be entered. The permissible adjustment range depends on the pin position according to the table on page 67. After initialization has been successfully completed, the maximum nominal travel/angle reached on initialization is displayed.
6*	<b>Init mode</b> [MAX] NOM MAN Sub ZP ESC	Select the initialization mode MAX: Maximum range of the control valve, the travel/angle of the closure member from the CLOSED position to the opposite stop in the actuator. NOM: Nominal range of the control valve, the travel/angle of the closure member measured from the CLOSED position to the indicated OPEN position. MAN: Manual adjustment: upper x-range value Sub: No self-adjustment (emergency mode) ZP: Zero calibration
7*	<b>w/x</b> [↗↗] ↗↘ ESC	Direction of action of the reference variable w in relation to the travel/angle of rotation x (increasing/increasing or increasing/decreasing) Automatic adaptation: AIR TO OPEN: On completion of initialization, the direction of action remains increasing/increasing (↗↗), a globe valve opens as the mA signal increases. AIR TO CLOSE: On completion of initialization, the direction of action changes to increasing/decreasing (↗↘), a globe valve closes as the mA signal increases.
8*	<b>Lower x-range value</b> 0.0 to 80.0 [0.0] % of the nominal range, Specified in mm or angle ° provided Code 4 is set ESC	Lower range value for the travel/angle of rotation in the nominal or operating range. The <b>operating range</b> is the actual travel/angle of the control valve and is limited by the lower x-range value (Code 8) and the upper x-range value (Code 9). Usually, the operating range and the nominal range are identical. The nominal range can be limited to the operating range by the lower and upper x-range values. Value is displayed or must be entered. The characteristic is adapted. See also the example in Code 9!

9*	<b>Upper x-range value</b> 20.0 to 100.0 [100.0] % nominal range, Specified in mm or angle ° provided Code 4 is set ESC	Upper range travel/angle of rotation in the nominal or operating range. Value is displayed or must be entered. The characteristic is adapted. Example: The operating range is modified, for example, to limit the range of a control valve which has been sized too large. For this function, the entire resolution range of the reference variable is converted to the new limits. 0 % on the display corresponds to the set lower limit and 100 % to the set upper limit.		
<b>Pin position table</b>		Pin position Code 4	Standard Code 5	Adjustment range Code 5
Specified in mm or angle ° for rotary actuators.  <b>Note!</b> If the pin distance has been selected too small with Code 4, the device switches to the SAFE mode for safety reasons.		<b>17</b> <b>25</b> <b>35</b> <b>50</b> <b>70</b> <b>100</b> <b>200</b> <b>90°</b>	7.5 7.5 15.0 30.0 40.0 60.0 120.0 90.0	3.6 to 17.7 5.0 to 25.0 7.0 to 35.4 10.0 to 50.0 14.0 to 70.7 20.0 to 100.0 40.0 to 200.0 24.0 to 110.0
10*	<b>Lower x-limit</b> [OFF] 0.0 to 49.9 % of the operating range ESC	Limitation of the travel/angle of rotation downwards to the entered value, the characteristic is not adapted.  The characteristic is not adapted to the reduced range. See also example in Code 11.		
11*	<b>Upper x-limit</b> [100 %] 50.0 to 120.0 [100] % of the operating range or OFF ESC	Limitation of the travel/angle of rotation upwards to the entered value, the characteristic is not adapted. Example: In some applications, it makes sense to limit the valve travel, e.g. if a certain minimum medium flow is required or a maximum flow must not be reached. The lower limit must be adjusted with Code 10, and the upper limit with Code 11. If a tight-closing function has been set up, it has priority over the travel limitation! When set to OFF, the valve can be opened past the nominal travel with a reference variable outside of the 4 to 20 mA range.		

12*	<b>w-start</b> 0.0 to 75.0 [0.0] % of the reference variable range ESC	<p>Lower range value of the applicable reference variable range must be smaller than the final value w-end, 0 % = 4 mA          The reference variable range is the difference between w-end and w-start, and must be <math>\Delta w \geq 25\% = 4 \text{ mA}</math>.</p> <p>For an adjusted reference variable range of 0 to 100 % = 4 to 20 mA, the control valve must move through its entire operating range from 0 to 100 % travel/angle of rotation.</p> <p>In <b>split-range operation</b>, the valves operate with smaller reference variables. The control signal of the control unit to control two valves is divided such, for instance, that the valves move through their full travel/angle of rotation at only half the input signal (first valve set to 0 to 50 % = 4 to 12 mA and second valve set to 50 to 100 % = 12 to 20 mA reference variable).</p>
13*	<b>w-end</b> 25.0 to 100.0 [100.0] % of the reference variable range ESC	<p>Upper range value of the applicable reference variable range, must be greater than w-start.          100 % = 20 mA</p>
14*	<b>Final position w &lt;</b> 0.0 to [1.0] % of the span adjusted via Code 12/13 OFF ESC	<p>If w reaches up to 1 % towards the final value that causes the valve to close, the actuator is immediately completely vented (with AIR TO OPEN) or filled with air (with AIR TO CLOSE). This action always lead to maximum tight-closing of the valve.</p> <p>Codes 14/15 have priority over Codes 8/9/10/11.</p>
15*	<b>Final position w &gt;</b> [OFF] 50.0 to 100.0 % of the span adjusted via Code 12/13 ESC	<p>If w reaches up to 99 % towards the final value that causes the valve to open, the actuator is immediately completely filled with air (with AIR TO OPEN) or vented (with AIR TO CLOSE). This action always lead to the valve being completely opened. Codes 14/15 have priority over Codes 8/9/10/11.          Example: Set the final position w &gt; to 99 % for three-way valves.</p>
16*	<b>Pressure limit</b> [OFF] 1.4 2.4 3.7 bar ESC	<p>The signal pressure can adopt the value of the applied supply pressure at the maximum [OFF] or it can be limited in stages of 1.4, 2.4 or 3.7 bar. This pressure limitation is already effective during the initialization.</p> <p><b>Note:</b> After changing a pressure limit already set, the actuator must be vented once (e.g. by selecting the fail-safe position over Code 0).</p>

17*	<b>K<sub>P</sub> step</b> 0 to 17 [7] ESC	Displaying or changing K <sub>P</sub> Note on changing the K <sub>P</sub> and T <sub>V</sub> steps: During the initialization of the positioner, the K <sub>P</sub> and T <sub>V</sub> values are optimized. Should the positioner show a tendency for impermissibly high post-pulse oscillation due to additional interference, the K <sub>P</sub> and T <sub>V</sub> steps can be adapted after the initialization. For this, either the T <sub>V</sub> step can be increased in increments until the desired response behavior is reached or, when the maximum value of 4 is reached, the K <sub>P</sub> step can be decreased in increments.  <b>CAUTION!</b> Changing the K <sub>P</sub> step influences the system deviation. This effect decreases as the K <sub>P</sub> step increases.
18*	<b>T<sub>V</sub> step</b> [2] 1 2 3 4 OFF ESC	Displaying or changing T <sub>V</sub> , See note under K <sub>P</sub> step A change of the T <sub>V</sub> step has no effect on the system deviation.
19*	<b>Tolerance band</b> 0.1 to 10.0 [5] % of the operating range ESC	Used for error monitoring Determination of the tolerance band in relation to the operating range. Associated lag time [30] s is a reset criterion. If, during initialization, a transit time is determined which is 6 times > 30 s, the 6fold transit time is accepted as lag time.
20*	<b>Characteristic</b> 0 to 9 [0] ESC	Select the characteristic: 0: Linear 1: Equal percentage 2: Reverse equal percentage 3: Butterfly valve linear 4: Butterfly valve eq. percentage 5: Rotary plug valve linear 6: Rotary plug valve eq. perc. 7: Segmented ball valve linear 8: Segmented ball valve eq. p. 9: User-defined * * Definition over SAMSON TROVIS-VIEW software or HART communication
21*	<b>w-ramp Open</b> 0 to 240 s [0] ESC	The time required to pass through the operating range when the valve opens. Limitation of the transit time (Code 21 and 22): For some applications it is recommendable to limit the transit time of the actuator to prevent it from engaging too fast in the running process.

22*	<b>w-ramp Closed</b> 0 to 240 s [0] ESC	The time required to pass through the operating range when the valve closes.
23*	<b>Total valve travel</b> 0 to 9999 [0] subsequently 10E3-99E7 RES ESC	Totaled double valve travel.  Can be reset to 0 via RES.
24*	<b>LV total valve travel</b> 1000 to 9999 [100 000] subsequently 10E3-99E7ESC	Limit value of total valve travel. If the limit value is exceeded, the fault symbol and the wrench symbol appear. Exponential display for 10 000 travel cycles onwards.
25*	<b>Alarm mode</b> 0 to 3 [2] ESC	Switching mode of software limit switches alarm A1 and A2 in responding state (when positioner initialized).  1) Explosion-protected version according to EN 60947-5-6 0: A1 $\geq$ 2.1 mA      A2 $\leq$ 1.2 mA 1: A1 $\leq$ 1.2 mA      A2 $\leq$ 1.2 mA 2: A1 $\geq$ 2.1 mA      A2 $\geq$ 2.1 mA 3: A1 $\leq$ 1.2 mA      A2 $\geq$ 2.1 mA  2) Version without explosion protection 0: A1 R = 348 $\Omega$ A2 Non-conducting 1: A1 Non-conducting    A2 Non-conducting 2: A1 R = 348 $\Omega$ A2 R = 348 $\Omega$ 3: A1 Non-conducting    A2 R = 348 $\Omega$  When a positioner has not been initialized, the software limit switches always register the signal as in the state of no response. If there is no mA signal at the terminals 11/12, the software limit switches both switch to $\leq$ 1.2 mA signal (Ex) or non-conducting (without explosion protection).
26*	<b>Limit value A1</b> OFF 0.0 to 100.0 [2.0] % of the operating range ESC	Displaying or changing the software limit value A1 in relation to the operating range. Setting has no effect when an inductive limit switch has been installed.

27*	<b>Limit value A2</b> OFF 0.0 to 100.0 [98.0] % of the operating range ESC	Displaying or changing the software limit value A2 in relation to the operating range.
28*	<b>Alarm Test</b> Reading direction: Standard            Turned [OFF]                [OFF] RUN 1                1 RUN RUN 2                2 RUN RUN 3                3 RUN ESC                    ESC	Testing the software limit switches alarm A1 and A2 in addition to the fault alarm contact A3. If the test is activated, the respective limit switches five times. RUN1/1 RUN: Software limit switch A1 RUN2/2 RUN: Software limit switch A2 RUN3/3 RUN: Fault alarm contact A3
29*	<b>Position transmitter x/ix</b> <sup>3)</sup> [↗↘] ↗↘ ESC	Operating direction of the position transmitter; indicates how the travel/angle position is assigned to the output signal i, based on the closed position. The operating range (see Code 8) of the valve is represented by the 4 to 20 mA signal. Values exceeding or falling below the limits 2.4 to 21.6 mA can be represented. When a positioner has not been initialized (reference variable less than 3.6 mA), the power consumption of the feedback signal is effective (current approx. 1.8 mA). When YES is set in Code 32, the position transmitter issues the value as per Code 30 during initialization or zero calibration. When NO is set in Code 32, 4 mA is issued during a running self-adaptation.
30*	<b>Fault alarm ix</b> <sup>3)</sup> [OFF] HI LO ESC	Used to select whether faults causing the fault alarm contact to switch should also be signaled through the position transmitter output and how they should be signaled HI ix > 21.6 mA or LO ix < 2.4 mA
31*	<b>Position transmitter test</b> <sup>3)</sup> -10.0 to 110.0 [x before the function is triggered] % of the operating range ESC	Testing the position transmitter. Values can be entered in relation to the operating range. The current actual value is used in initialized positioners locally as the start value (bumpless changeover to the test mode). On testing over software, the entered simulation value is issued as the position feedback signal for 30 seconds.
<sup>3)</sup> Analog position transmitter: Code 29/30/31 can only be selected if the position transmitter (optional) is installed.		

32*	<b>Display special functions</b> NO [YES] ESC	Fault alarm via display and fault alarm contact for special functions, e.g. zero calibration, initialization and position transmitter test (Code 31).
33*	<b>Display total valve travel</b> NO [YES] ESC	Fault alarm via display and fault alarm contact when the limit value for the total valve travel is exceeded.
34*	<b>Closing direction</b> CL [CCL] ESC	CL: Clockwise, CCL: Counterclockwise Turning direction in which the valve is moved to the Closed position (view onto the rotary switch motion when the positioner cover is open). Needs only be entered in initialization mode SUB (Code 6).
35*	<b>Blocking position</b> [0] mm/° /% ESC	Entering the blocking position. Distance up to the Closed position. Only necessary in initialization mode SUB.
36*	<b>Reset</b> [OFF] RUN ESC	Resets all parameters to default (factory setting). <b>Note:</b> After setting <b>RUN</b> , the positioner must be re-initialized.
37	<b>Position transmitter</b> Yes No	Display only, indicates whether the position transmitter option is installed.
38*	<b>Inductive alarm</b> [NO] YES ESC	Indicates whether the inductive limit switch option is installed or not.
39	<b>System deviation e info</b> -99.9 to 999.9 % ,	Display only, indicates the deviation from the set point position.
40	<b>Transit time Open info</b> 0 to 240 s [0]	Display only, minimum opening time is determined during initialization
41	<b>Transit time Closed info</b> 0 to 240 s [0]	Display only, minimum closing time is determined during initialization
42	<b>Auto-w info</b> 0.0 to 100.0 % of the span 4 to 20 mA	Display only, indicates the supplied automatic reference variable corresponding 4 to 20 mA.
43	<b>Firmware info</b> Xxxx	Display only, indicates the current firmware version of the positioner.



44	<b>y info</b> [0] OP 0 to 100 % MAX	Display only, blocked prior to initialization. After initialization: indicates the actuator pressure in %. 0 to 100 % corresponds to the pressure range which adjusts the travel/angle range from 0 to 100 %. If the actuator pressure is 0 bar, e.g. due to tight-closing on bottom or fail-safe action, <b>OP</b> appears on the display. If the actuator pressure is higher than the pressure required for X = 100 %, e.g. due to tight-closing on top, <b>MAX</b> appears on the display. Value is determined during initialization.
45	<b>Solenoid valve info</b> Yes No	Display only, indicates whether a solenoid valve is installed.
46*	<b>Polling address</b> 0 to 63 [0] ESC	Select bus address
47*	<b>Write protection HART</b> YES [NO] ESC	When the write protection function is activated, device data can only be read, but not overwritten over HART communication.
<b>Error codes – Remedy</b>		Fault alarm symbol active, when prompted, <b>Err</b> appears. If any fault messages exist, they are displayed here.
Initialization error (indicated by the fault symbol on the display)		
50	<b>x &lt; range</b>	The value supplied by the measuring signal is either too high or too low, the measuring sensor is close to its mechanical limit. <ul style="list-style-type: none"> <li>• Pin positioned incorrectly.</li> <li>• Bracket slipped in case of NAMUR attachment or positioner is not central.</li> <li>• Follower plate incorrectly attached.</li> </ul>
	Remedy	Check attachment and pin position, set operating mode from SAFE to MAN and re-initialize the positioner.

51	<b>x &gt; range</b>	<p>The measuring span of the sensor is too low.</p> <ul style="list-style-type: none"> <li>• Pin positioned incorrectly.</li> <li>• Wrong lever.</li> </ul> <p>A rotational angle smaller than 11° at the positioner shaft creates just an alarm. An angle below 6° leads to the initialization being canceled.</p>
	Remedy	Check attachment and re-initialize the positioner.
52	<b>Attachment</b>	<ul style="list-style-type: none"> <li>• Positioner attachment incorrect.</li> <li>• Nominal travel/angle (Code 5) could not be achieved on initialization under NOM or SUB (no tolerance downwards permissible)</li> <li>• Mechanical or pneumatic error, e.g. wrong lever selected or supply pressure too low to move to the required position or pneumatic fault</li> </ul>
	Remedy	<p>Check attachment and supply pressure. Re-initialize the positioner.</p> <p>Under certain circumstances, it may be possible to check the maximum travel/angle by entering the actual pin position and then performing an initialization under MAX.</p> <p>After initialization has been completed, the Code 5 indicates the maximum achieved travel or angle.</p>
53	<b>Init time &gt;</b>	<p>The initialization routine lasts too long. The positioner returns to its previous operating mode.</p> <ul style="list-style-type: none"> <li>• No pressure on the supply line or there is a leak.</li> <li>• Supply air failure during initialization.</li> </ul>
	Remedy	<p>Check attachment and supply pressure.</p> <p>Re-initialize the positioner.</p>
54	<b>Init – Solenoid valve</b>	<ol style="list-style-type: none"> <li>1) A solenoid valve is installed (Code 45 = YES) and was not or not properly connected so that an actuator pressure could not be built up. The message appears when you attempt to initialize the positioner.</li> <li>2) If you attempt to initialize the device from the fail-safe position (SAFE).</li> </ol>
	Remedy	<p>Re. 1) Check connection and supply voltage of the solenoid valve.</p> <p>Re. 2) Set the <b>MAN</b> operating mode over Code 0. Then initialize the positioner.</p>

55	<b>Transit time &lt;</b>	The actuator transit times determined during the initialization are so short that the positioner cannot adapt itself optimally.
	Remedy	Check the volume restriction setting as described in section 5.2, re-initialize the positioner.
56	<b>Pin pos.</b>	Initialization was canceled because you are required to enter the pin position for the selected initialization modes <b>NOM</b> and <b>SUB</b> .
	Remedy	Enter pin position over Code 4 and nominal travel/angle over Code 5. Re-initialize the positioner.
Operating error (indicated by the fault symbol on the display)		
57	<b>Control loop</b>	Control loop fault, the control valve does not react within the tolerable times of the controlled variable (tolerance band alarm Code 19).
	Additional message at the fault alarm contact!	<ul style="list-style-type: none"> <li>• Actuator mechanically blocked.</li> <li>• Attachment of the positioner subsequently postponed.</li> <li>• Supply pressure not sufficient.</li> </ul>
	Remedy	Check attachment.
58	<b>Zero point</b>	Zero point incorrect. Error may arise when the mounting position/linkage of the positioner moves or when the valve seat trim is worn, especially with soft-sealed plugs.
	Remedy	Check valve and mounting of the positioner. If OK, perform a zero calibration over Code 6 (see section 5.9 on page 56).
59	<b>Auto correction</b>	Should an error occur in the data range of the positioner, the self-monitoring function recognizes it and automatically corrects it.
	Remedy	Automatic
60	<b>Fatal error</b>	An error was detected in the data relevant for safety, auto correction is not possible. This may be due to EMC disturbances. The control valve is moved to the fail-safe position.
	Additional message at the fault alarm contact!	
	Remedy	Reset over Code 36. Re-initialize the positioner.
Hardware error (indicated by the fault symbol on the display)		

62	<b>x signal</b>	Determination of the measured value for the actuator has failed. Conductive plastic element is defective. The positioner continues to run in emergency mode, but should be replaced as soon as possible. The emergency mode on the display is indicated by a blinking control symbol and 4 dashes instead of the position indication. Note on the control: If the measuring system has failed, the positioner is still in a reliable state. The positioner switches to emergency mode where the position cannot be accurately controlled anymore. However, the positioner continues operation according to its reference variable signal so that the process remains in a safe state.
	Additional message at the fault alarm contact!	Remedy Return the positioner to SAMSON AG for repair.
63	<b>w too small</b>	The reference variable is much smaller than 4 mA (0 %); occurs if the power source that drives the positioner does not comply with the standard. This state is indicated on the positioner display by a blinking <b>LOW</b> .
	Remedy	Check reference variable. If necessary, limit the current source downwards so that no values below 4 mA can be issued.
64	<b>i/p converter (y)</b>	The circuit of the i/p converter has been interrupted.
	Remedy	Cannot be remedied. Return the positioner to SAMSON AG for repair.

Error appendix		
65	<b>Hardware</b> Additional message at the fault alarm contact!	A hardware error has occurred, the positioner moves to the fail-safe position <b>SAFE</b> .
	Remedy	Confirm error and return to the automatic operating mode, or perform a reset and re-initialize the device. If this is not successful, return device to SAMSON AG for repair.
66	<b>Data memory</b> Additional message at the fault alarm contact!	The writing of data to the data memory does not work anymore, e.g. when the written data deviate from the read data. Valve moves to the fail-safe position.
	Remedy	Return the positioner to SAMSON AG for repair.
67	<b>Test calculation</b> Additional message at the fault alarm contact!	The hardware positioner is monitored by means of a test calculation.
	Remedy	Confirm error. If this is not possible, return the positioner to SAMSON AG for repair.
Data error		
68	<b>Control parameter</b> Additional message at the fault alarm contact!	Control parameter error, e.g. due to EMC disturbances.
	Remedy	Confirm error, perform reset and re-initialize the positioner.
69	<b>Poti parameter</b> Additional message at the fault alarm contact!	Parameter error of the digital potentiometer.
	Remedy	Confirm error, perform reset and re-initialize the positioner.
70	<b>Calibration</b> Additional message at the fault alarm contact!	Error in the production calibration data, e.g. due to EMC disturbances. Subsequently, the device runs on default values
	Remedy	Return the positioner to SAMSON AG for repair.
71	<b>General parameters</b>	Parameter errors that are not critical for the control.
	Remedy	Confirm error. Check and, if necessary, reset required parameters.

72	<b>Start-up parameters</b>	Start-up parameter errors
	Remedy	Confirm error, perform reset and re-initialize the positioner.
73	Internal device error 1	Internal device error
	Remedy	Return the positioner to SAMSON AG for repair.
74	HART parameters	Error in the HART parameters that are not critical for the control function.
	Remedy	Confirm error. Check and, if necessary, reset required parameters.
75	Info parameters	Error in the info parameters that are not critical for the control function.
	Remedy	Confirm error. Check and, if necessary, reset required parameters.
76	<b>No emergency mode</b>	The travel measuring system of the positioner has a self-monitoring function (see Code 62). A controlled emergency mode is not available on certain actuators, such as double-acting actuators. For this reason, the positioner moves into the fail-safe position when a measuring error occurs. During the initialization, the positioner checks whether the actuator has such a function or not.
	Remedy	Merely information, confirm, if necessary. No further action necessary.
77	<b>Program loading error</b> Additional message at the fault alarm contact!	When the device starts operation for the first time after the input signal has been applied, it carries out a self-test ( <b>tEstinG</b> runs across the display). If the device loads a program that does not correspond to that of the positioner, the valve is moved into the fail-safe position. It is not possible to make the valve leave this fail-safe position again by operating the positioner.
	Remedy	Interrupt current and restart positioner. Otherwise, return the positioner to SAMSON AG for repair.
78	<b>Options parameter</b>	Errors in options parameters, e.g. due to EMC disturbances.
	Remedy	Return the positioner to SAMSON AG for repair.

## 12 Dimensions in mm

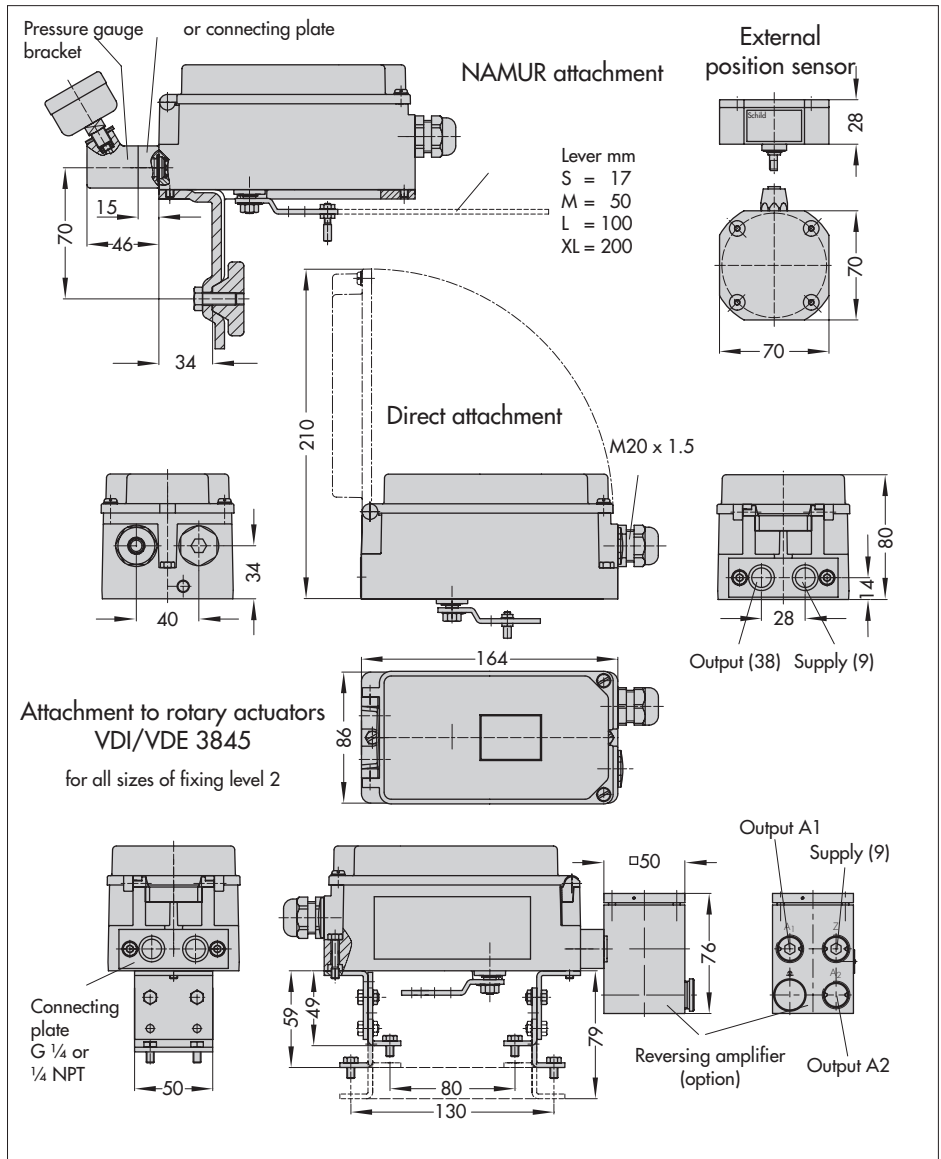





## TRANSLATION

### EC TYPE EXAMINATION CERTIFICATION

- (1)
- (2) Equipment and Protective Systems Intended for Use in Potentially Explosive Atmospheres – **Directive 94/9/EC**
- (3) EC Type Examination Certificate Number

#### PTS 02 ATEX 2174

- (4) Equipment: HART® capable positioner Type 3730-31
- (5) Manufacturer: SAMSON AG Mess- und Regeltechnik
- (6) Address: Weismüllerstr. 3, D-60314 Frankfurt, Germany
- (7) This equipment and any acceptable variation thereof are specified in the schedule to this certificate.
- (8) The Physikalisch-Technische Bundesanstalt, notified body number 0102, in accordance with Article 9 of the Council Directive 94/9/EC of 23 March 1994, certifies that this equipment has been found to comply with the Essential Health and Safety Requirements relating to the design and construction of equipment and protective systems intended for use in potentially explosive atmospheres given in Annex II to the Directive.

The examination and test results are recorded in confidential report  
**PTB Ex. 02-22323.**

- (9) The Essential Health and Safety Requirements are satisfied by compliance with

**EN 50014: 1997**      **EN 50020: 1994**

- (10) If the sign "X" is placed after the certificate number, it indicates that the equipment is subject to special conditions for safe use specified in the schedule to this certificate.

---

EC Type Examination Certificates without signature and seal are invalid.  
This EC Type Examination Certificate may only be reproduced in its entirety and without any changes, schedule included.  
Errors or changes shall require the prior approval of the Physikalisch-Technische Bundesanstalt.

Physikalisch-Technische Bundesanstalt, Bundesallee 100, D-38116 Braunschweig

Page 1/6

PTB32-3730.doc

- (11) According to the Directive 94/9/EC, this EC TYPE EXAMINATION CERTIFICATE relates only to the design and construction of the specified equipment. If applicable, further requirements of this Directive apply to the manufacture and supply of the equipment.

- (12) The marking of the equipment shall include the following:



Zertifizierungsstelle Explosionsschutz      Braunschweig, 02. Dezember 2002  
By order

(Signature)      (Seal)

Dr.-Ing. U. Johannsmeyer  
Regierungsdirktor

---

EC Type Examination Certificates without signature and seal are invalid.  
This EC Type Examination Certificate may only be reproduced in its entirety and without any changes, schedule included.  
Errors or changes shall require the prior approval of the Physikalisch-Technische Bundesanstalt.

Physikalisch-Technische Bundesanstalt, Bundesallee 100, D-38116 Braunschweig

Page 2/6

PTB32-3730.doc

Schedule

(13)

(14) EC TYPE EXAMINATION CERTIFICATE No. PTB 02 ATEX 2174

(15) Description of Equipment

The HART® capable positioner Type 3730-31 is a single- or double-acting positioner with communication capability intended for attachment to all current linear or rotary actuators. It serves for adjusting valve stem position to the control signal.

In the 3730-31... version communication is according to the SSP (SAWSON Serial Inheritance Protocol) and the HART protocol.

The HART® capable positioner Type 3730-31 is a passive two-terminal network which may be connected to any certified intrinsically safe circuit, provided the permissible maximum values of  $U_i$ ,  $I_i$  and  $P_i$  are not exceeded.

For instrument air non-combustible media are used.

The device is intended for use inside and outside of hazardous areas.

The correlation between temperature classification and permissible ambient temperature ranges are shown in the table below:

Temperature class	Permissible ambient temperature range
T6	-40 °C ... 60 °C
T5	-40 °C ... 70 °C
T4	-40 °C ... 80 °C

Electrical data

Signal circuit  
(terminals 11/12)

Type of protection: Intrinsic safety EEx ia IIC  
only for connection to a certified  
intrinsically safe circuit

Maximum values:

$U_i = 28 \text{ V}$

$I_i = 115 \text{ mA}$

$P_i = 1 \text{ W}$

$C_i = 5.3 \text{ nF}$ ,  $L_i =$  negligible

EC Type Examination Certificates without signature and seal are invalid.  
This EC Type Examination Certificate may only be reproduced in its entirety and without any changes, schedule included.  
Extracts or changes shall require the prior approval of the Physikalisch-Technische Bundesanstalt.

Software limit switches  
(terminals 41/42, 51/52)

Type of protection: Intrinsic safety EEx ia IIC  
only for connection to a certified intrinsically safe  
circuit

Maximum values:

$U_i = 20 \text{ V}$

$I_i = 60 \text{ mA}$

$P_i = 230 \text{ mW}$

$C_i = 5.3 \text{ nF}$ ,  $L_i =$  negligible

Limit switch, inductive  
(terminals 41/42)

Type of protection: Intrinsic safety EEx ia IIC  
only for connection to a certified intrinsically safe  
circuit

Maximum values:

$U_i = 1.6 \text{ V}$

$I_i = 52 \text{ mA}$

$P_i = 1.69 \text{ mW}$

$C_i = 60 \text{ nF}$ ,  $L_i = 200 \text{ } \mu\text{H}$ , or

$U_i = 1.6 \text{ V}$

$I_i = 25 \text{ mA}$

$P_i = 64 \text{ mW}$

$C_i = 60 \text{ nF}$ ,  $L_i = 200 \text{ } \mu\text{H}$

The correlation between temperature classification, permissible ambient temperature ranges and maximum short-circuit current for analysers is shown in the table below:

Temperature class	Permissible ambient temperature range	$I_b / P_b$
T6	-40 °C ... 45 °C	52mA/1.69mW
T5	-40 °C ... 60 °C	
T4	-40 °C ... 75 °C	
T6	-40 °C ... 60 °C	25mA/0.64mW
T5	-40 °C ... 80 °C	
T4	-40 °C ... 80 °C	

EC Type Examination Certificates without signature and seal are invalid.

This EC Type Examination Certificate may only be reproduced in its entirety and without any changes, schedule included.  
Extracts or changes shall require the prior approval of the Physikalisch-Technische Bundesanstalt.

Fault alarm output  
(terminals 83/84)

Type of protection: Intrinsic safety EXe ia IIC  
only for connection to a certified intrinsically safe  
circuit

**Maximum values:**

- U = 20 V
- Ii = 60 mA
- P = 250 mW
- CI = 5.3 nF, Ui = negligible

Serial interface BU

Type of protection: Intrinsic safety EXe ia IIC

**Maximum values:**

- Uo = 7.88 V
- Io = 61.8 mA
- Po = 120 mW, Linear characteristic
- Co = 0.65 µF, Ui = 10 mH

only for connection to a certified  
intrinsically safe circuit

- Uo = 1.6 V
- Ii = 2.5 mA
- Pi = 64 mW
- CI = negligible,
- Li = negligible

For interconnecting the rules for interconnecting intrinsically safe circuit shall be  
complied with.

External position sensor  
(analog pcb, pins, p7, p10,  
p11)

Type of protection: Intrinsic safety EXe ia IIC

**Maximum values:**

- Uo = 7.88 V
- Io = 61 mA
- Po = 120 mW, Linear characteristic
- Co = 0.66 µF, Ui = 10 mH
- CI = 730 nF, Li = 370µH

EC Type Examination Certificate without signature and seal are invalid.  
This EC Type Examination Certificate may only be reproduced in its entirety and without any changes, schedule included.  
Extracts or changes shall require the prior approval of the Physikalisch-Technische Bundesanstalt.

(16) Test Report: **PTB Ex 02-22323**

(17) **Special conditions for safe use**

Not applicable

(18) **Special Health and Safety Requirements**

In compliance with the standards specified above

Braunschweig, 02 December 2002

Zertifizierungsstelle Explosionsschutz

By order

(Signature) (seal)

Dr. Ing. U. Johannsmeyer  
Regierungsdirektor

EC Type Examination Certificate without signature and seal are invalid.  
This EC Type Examination Certificate may only be reproduced in its entirety and without any changes, schedule included.  
Extracts or changes shall require the prior approval of the Physikalisch-Technische Bundesanstalt.

Physikalisch-Technische Bundesanstalt  
Braunschweig und Berlin



## TRANSLATION

### ADDENDUM No.: 1

in compliance with Directive 94/9/EC Annex III Clause 6  
to the EC Type Examination certificate PTB 02 ATEX 2174

**Equipment:** Model 3730-31.. HART-capable Positioner  
**Marking:** II 2 G EEx ia IIC T6  
**Manufacturer:** SAMSON AG  
**Address:** Weismüllerstr. 3, D-60314 Frankfurt, Germany

#### Description of the additions and modifications:

In future the Model 3730-31... HART-capable Positioner is permitted to be manufactured also in compliance with the documents listed below.

The modem board will be modified and the optional "Forced Venting Function" will be added. The electrical data will be supplemented as follows:

#### Electrical data

**Forced venting function (terminal 81/82)**  
Type of protection: intrinsic safety EEx ia IIC  
only for connection to a certified intrinsically safe circuit

Maximum values:

U<sub>i</sub> = 28 V  
I<sub>i</sub> = 115 mA  
P<sub>i</sub> = 500 mW

L: negligible  
C: = 5.3 nF

---

EC Type Examination Certificates without signature and seal are invalid.  
This EC Type Examination Certificate may only be reproduced in its entirety and without any changes, selective included.  
Errors or changes shall require the prior approval of the Physikalisch-Technische Bundesanstalt.

Physikalisch-Technische Bundesanstalt, Bundesallee 100, D-38116 Braunschweig

PTB02-3730-31Add-1.doc

PTB

Physikalisch-Technische Bundesanstalt  
Braunschweig und Berlin

Addendum No. 1 to the EX Type Examination Certificate PTB 02 ATEX 2174

All the other electrical data and particulars specified in the EC Type Examination Certificate apply unchanged also to this Addendum No. 1.

**Test report:** PTB EX 03-23171

Zertifizierungsstelle Explosionsschutz  
By order Braunschweig, 18 June 2002

(Signature) (Seal)

Dr. Ing. U. Johannsmeyer  
Regierungsdirktor

---

EC Type Examination Certificates without signature and seal are invalid.  
This EC Type Examination Certificate may only be reproduced in its entirety and without any changes, selective included.  
Errors or changes shall require the prior approval of the Physikalisch-Technische Bundesanstalt.

Physikalisch-Technische Bundesanstalt, Bundesallee 100, D-38116 Braunschweig

PTB02-3730-31Add-1.doc

**ADDENDUM N o.: 2**

in compliance with Directive 94/9/EC Annex III Clause 6  
to the EC Type Examination Certificate PTB 02.ATEX 2174

**Equipment:** Model 3730-31 ... HART capable Positioner  
**Marking:**  II 2G Ex ia IIC T6  
**Manufacturer:** SAMSON AG  
**Address:** Weismüllerstr. 3, D-60314 Frankfurt, Germany

Description of the additions and modifications

The Model 3731-31 ... HART capable Positioner is permitted to be manufactured in future also in compliance with the documents specified in the attached test report PTB Ex 04-23430.

Attachment to pneumatic control valves or butterfly valves is either directly to the Series 3277 Actuators or by means of NAMUR adapter plates to actuators of conventional design.

The modifications relate to the internal and external design.

- a) The Model 3730-31 ... HART capable Positioner satisfies the requirements of EN 50281-1-1 : -1998 relating to electrical apparatus with protection provided by enclosures. According to this standard, the positioner shall be provided in addition with the following marking:
- 
- b) The circuitry of the multifunction printed circuit board will be modified and the position indicator will be added (version 3730-1...1). The electrical data will be supplemented as follows:

This EC Type Examination Certificate without signature and seal is invalid.  
This EC Type Examination Certificate may only be reproduced in full or in part for any other purpose without the prior approval of the Physikalisch-Technische Bundesanstalt.  
Extract or changes that require the prior approval of the Physikalisch-Technische Bundesanstalt.

Physikalisch-technische Bundesanstalt, Bundesallee 100, D-38116 Braunschweig

PH32AG42.doc

Electrical data

Signal circuit Type of protection: Intrinsic safety Ex ia IIC  
Only for connection to a certified intrinsically safe circuit

Maximum values:  
U<sub>i</sub> = 28 V  
I<sub>i</sub> = 11,5 mA  
P<sub>i</sub> = 1 W  
L<sub>i</sub> negligible  
C<sub>i</sub> = 35 nF

Version 3730-1-1

Position indicator Type of protection: Intrinsic safety Ex ia IIC  
(terminals 31/32) Only for connection to a certified intrinsically safe circuit

Maximum values:  
U<sub>i</sub> = 28 V  
I<sub>i</sub> = 11,5 mA  
P<sub>i</sub> = 1 W  
L<sub>i</sub> negligible  
C<sub>i</sub> = 5,3 nF

All the other electrical data and information contained in the EC Type Examination Certificate apply unchanged also to this Addendum No. 2.

Test report: **PTB Ex 04-23430**

Zertifizierungsstelle Explosionschutz Braunschweig, 16 February 2004  
By order

(Signature) (Seal)

Dr. Ing. U. Gerlach

This EC Type Examination Certificate without signature and seal is invalid.  
This EC Type Examination Certificate may only be reproduced in full or in part for any other purpose without the prior approval of the Physikalisch-Technische Bundesanstalt.  
Extract or changes that require the prior approval of the Physikalisch-Technische Bundesanstalt.

Physikalisch-technische Bundesanstalt, Bundesallee 100, D-38116 Braunschweig

PH32A44-2.doc



## TRANSLATION

### Statement of Conformity

- (1) Equipment and Protective Systems Intended for Use in Potentially Explosive Atmospheres – **Directive 94/9/EC**
- (3) EC Type Examination Certificate Number

#### PTB 03 ATEX 2180 X

- (4) Equipment: Model 3730-38 HART-capable Positioner
- (5) Manufacturer: SAMSON AG Mess- und Regeltechnik
- (6) Address: Weismüllerstr. 3, 60314 Frankfurt am Main, Germany
- (7) The equipment and any acceptable variation thereof are specified in the schedule to this certificate and the documents referred to therein.

(8) The Physikalisch-Technische Bundesanstalt, notified body number 0102 according to Article 9 of the Council Directive 94/9/EC of 23 March 1994, certifies that this equipment has been found to comply with the essential health and safety requirements relating to the design and construction of equipment and protective systems intended for use in potentially explosive atmospheres specified in Annex II to the Directive.

The examination and test results are recorded in confidential report.

#### PTB Ex 03-23301

(9) The essential health and safety requirements are satisfied by compliance with

#### EN 50021 : 1999

- (10) If the sign "X" is placed after the certificate number, it indicates that the equipment is subject to special conditions for safe use as specified in the schedule to this certificate.
- (11) In compliance with the Directive 94/9/EC this Statement of Conformity relates only to the design and construction of the equipment specified. Further requirements of this Directive apply to manufacture and marketing of this equipment.

Statements of Conformity without signature and seal are invalid.  
This Statement of Conformity may be reproduced only in its entirety without any changes.  
Errors or changes shall require the prior approval of the Physikalisch-Technische Bundesanstalt.

Physikalisch-Technische Bundesanstalt Bundesallee 100 D-38116 Braunschweig **PTB37Ex n.d.doc**



(12) The marking of the equipment shall include the following:



Zertifizierungsstelle Explosionschutz  
By order

(Signature) (Seal)

Dr.-Ing. U. Johannsmeyer  
Regierungsdirektor

Braunschweig, .....

Statements of Conformity without signature and seal are invalid.  
This Statement of Conformity may be reproduced only in its entirety without any changes.  
Errors or changes shall require the prior approval of the Physikalisch-Technische Bundesanstalt.

Physikalisch-Technische Bundesanstalt Bundesallee 100 D-38116 Braunschweig **PTB37Ex n.d.doc**

(13)

**S c h e d u l e**

(14)

**Statement of Conformity PTB 03 ATEX 2180 X**

(15)

**Description of Equipment**

The Model 3730-38... HART-capable Positioner is a single- or double-acting positioner with communication capability intended for attachment to any current linear or rotary actuator. It serves for translating control signals into valve stem positions.

The Model 3730-38... version is capable of communicating according to the SSP and the HART protocol.

For instrument air non-combustible media are used.

The device is intended for use inside and outside of hazardous locations.

The correlation between temperature classification and permissible temperature ranges is shown in the table below.

Temperature class	Permissible ambient temperature range
T6	-40°C...60°C
T5	-40°C...70°C
T4	-40°C...80°C

**Electrical data**

Signal circuit (terminals 11/12) Type of protection EEx nA II

Software limit switch (terminals 41/42, 51/52) Type of protection EEx nA II

Inductive limit switch (terminals 41/42) Type of protection EEx nA II

Forced venting function (terminals 81/82) Type of protection EEx nA II

Fault alarm output (terminals 83/84) Type of protection EEx nA II

Serial interface adapter Type of protection EEx nA II

External position sensor (analog board, pins p9, p10, p11) Type of protection EEx nA II

(16) Test report **PTB Ex\_03-23301**

(17) **Special conditions for safe use**

The signal circuit (terminals 11/12) shall be preceded by a fuse installed outside of the hazardous locations. This fuse shall comply with IEC 60127-2/II, 250 V F, or with IEC 60127-2/VI, 250 T, with a fuse nominal current of  $I_N \leq 63$  mA.

The serial interface adapter shall be preceded in the Vcc connection by a fuse in compliance with IEC 60127-2/II, 250 V F, or with IEC 60127-2/VI, 250 T, with a fuse nominal current of  $I_N \leq 40$  mA.

The serial interface adapter shall be installed outside the hazardous location.

The Model 3730-38... HART-capable Positioner shall be mounted in an enclosure providing at least Degree of Protection IP 54 in compliance with the IEC Publication 60529. This requirement applies also to cable entries and/or cable couplers...

The wiring shall be connected in such a manner that the connection facilities are not subjected to pull and/or twisting.

(18) **Basis health and safety requirements**

Are satisfied by compliance with the standard specified above.

Zertifizierungsstelle Explosionschutz  
By order Braunschweig, .....

(Signature) (seal)

Dr. Ing. U. Johannsmeyer  
Regierungsdirektor

## Installation Manual for apparatus certified by CSA for use in hazardous locations.

Electrical rating of intrinsically safe apparatus and apparatus for installation in hazardous locations.

Table 1: Maximum values

Circuit No.	Control signal	Position indicator	Forced venting Solenoid valve	Limit switches		Fault signal
				Limit switches inductive	Limit switches software	
	1	2	5	3 and 4	3 and 4	6
Terminal No.	11 / 12	31 / 32	81 / 82	41 / 42 and 51 / 52	41 / 42 and 51 / 52	83 / 84
U <sub>0</sub> or V <sub>max</sub>	28V	28V	28V	16V	20V	20V
I <sub>0</sub> or I <sub>max</sub>	115mA	115mA	115mA	2552 mA	60mA	60mA
P <sub>0</sub> or P <sub>max</sub>	1W	1W	500mW	64(169 mW)	250mW	250mW
C <sub>i</sub>	35nF	5.3nF	5.3nF	60nF	13.3nF	13.3nF
L <sub>i</sub>	0µH	0µH	0µH	100µH	0µH	0µH

Circuit	Serial interface BU		External position sensor	
	Connector		Analog pcb pin p9, p10, p11	
U <sub>0</sub> or V <sub>max</sub>	16V	U <sub>0</sub> or V <sub>cc</sub>	7.88V	U <sub>0</sub> or V <sub>cc</sub>
I <sub>0</sub> or I <sub>max</sub>	25mA	I <sub>0</sub> or I <sub>sc</sub>	61.8mA	I <sub>0</sub> or I <sub>sc</sub>
P <sub>0</sub> or P <sub>max</sub>	64mW	P <sub>0</sub>	120mW	P <sub>0</sub>
C <sub>i</sub>	0nF	C <sub>0</sub>	0.65µF	C <sub>0</sub>
L <sub>i</sub>	0µH	L <sub>0</sub>	10mH	L <sub>0</sub>
				C <sub>i</sub> =730nF L <sub>i</sub> =370µH

Notes: Entity parameters must meet the following requirements:

U<sub>0</sub> or V<sub>cc</sub> or V<sub>i</sub> ≤ U<sub>0</sub> or V<sub>max</sub> / I<sub>0</sub> or I<sub>sc</sub> or I<sub>i</sub> ≤ I<sub>0</sub> or I<sub>max</sub> / P<sub>0</sub> or P<sub>max</sub> ≤ P<sub>0</sub> or P<sub>max</sub>  
C<sub>0</sub> ≥ C<sub>i</sub> + Cable and L<sub>0</sub> ≥ L<sub>i</sub> + L<sub>cable</sub>

Table 2: CSA/FM - certified barrier parameters of circuit 2 and 5

Barrier	Supply barrier				Evaluation barrier			
	V	R	I	P	V	R	I	
circuit 2	≤28V	≥300Ω	≤115mA	≤1W	≤28V	#	#	0mA
circuit 5	≤28V	≥302Ω	≤115mA	≤500mW	≤28V	#	#	0mA

Table 3: The correlation between temperature classification and permissible ambient temperature ranges is shown in the table below:

Temperature class	Permissible ambient temperature range
T6	-40°C ... 60°C
T5	-40°C ... 70°C
T4	-40°C ... 80°C

Table 4: For the Model 3730 - 331 ... Positioner the correlation between temperature classification, permissible ambient temperature ranges and maximum short-circuit current is shown in the table below:

Temperature class	Permissible ambient temperature range	Maximum short-circuit current
T6	-40°C ... 45°C	52mA
T5	-40°C ... 60°C	
T4	-40°C ... 75°C	
T6	-40°C ... 60°C	25mA
T5	-40°C ... 80°C	
T4	-40°C ... 80°C	



Intrinsically safe if installed as specified in manufacturer's installation manual.

CSA - certified for hazardous locations

Ex ia IIC T6; Class I, Zone 0

Class I, Div. 1, Groups A, B, C, D,

Class II Div. 1, Groups E, F + G;

**Type 4 Enclosure**

**Notes:**

- 1.) The apparatus may be installed in intrinsically safe circuits only when used in conjunction with CSA certified apparatus. For maximum values of  $U_i$  or  $V_{max}$ ,  $I_i$  or  $I_{max}$ ,  $P_i$  or  $P_{max}$ ;  $C_i$  and  $L_i$  of the various apparatus see Table 1 on page 1.
- 2.) For barrier selection see Table 2 on page 2.
- 3.) The installation must be in accordance with the C. E. C. Part 1.
- 4.) Use only supply wires suitable for 5°C above surrounding temperature.
- 5.) For CSA Certification, Safety Barrier must be CSA Certified and installed in accordance with C.E.C. Part. 1. Each pair of I.S. wires must be protected by a shield that is grounded at the I.S. Ground. The shield must extend as close to the terminals as possible.

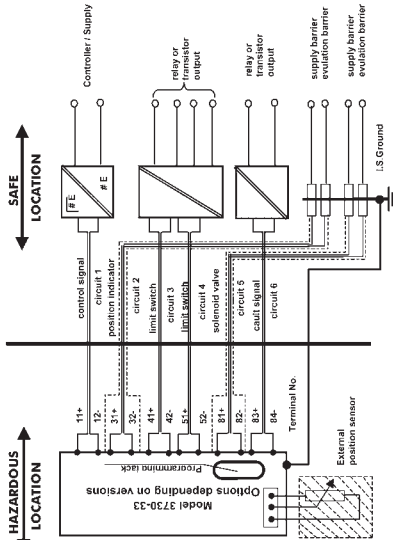

**Controller CSA/FM - certified**  
**Relay or transistor output 1 or 2 channel(s) resp. CSA/FM - certified**  
**Supply and evaluation barrier CSA/FM - certified**

For the permissible maximum values for the intrinsically safe circuits 1,3,4 and 6 see Table 1  
 For the permissible barrier parameters for the circuits 2 and 5 see Table 2  
 Cable entry M 20 x 1,5 or mild conduit according to drawing No. 1050 - 0539 T  
 or 1050 - 0540 T

On interconnection to form ground- free signal circuits, only evaluation barriers must be installed in the return line. Correct polarity must be ensured.

**Circuit diagram of a ground- free signal circuit**  
 (position indicator and forced venting function)

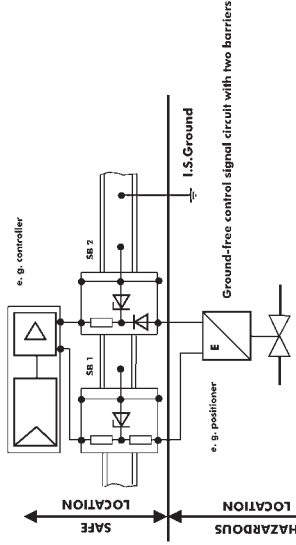

In grounded signal circuits with only one barrier, the return line must be grounded or included in the potential equalization network of the system.

**Circuit diagram of a grounded signal circuit**  
 (position indicator and forced venting function)

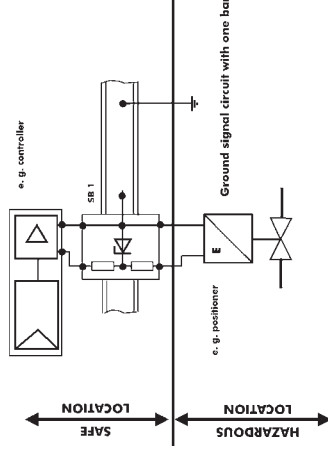

CSA - certified for hazardous locations  
 Class I, Zone 2  
 Class I, Division 2, Groups A, B, C, D,  
 Class II, Groups E, F, G.

**Type 4 Enclosure**

HART-capable positioner with position indicator, forced venting function (solenoid valve), fault signal and limit switches.

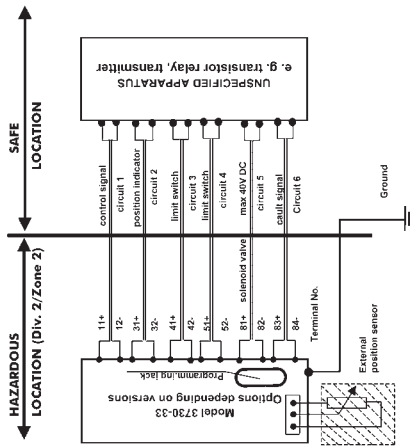

**Notes:**

- 1.) The installation must be in accordance with the Canadian Electrical Code, Part 1
- 2.) For the maximum values for the individual circuits see Table 1 and 2.
- 3.) The cables shall be protected by conduits.
- 4.) Cable entry only rigid metal conduit according to drawing No. 1050-0539 T and 1050-0540 T

**Installation drawing Control Relay KHA5-OTI/Ex2, KHA6-OTI/Ex1 or KHA6-OTI/Ex2 with Model SJ-b-N Proximity Sensors**

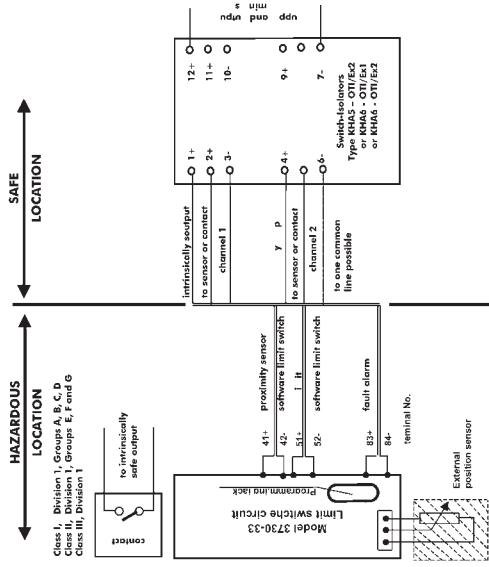

maximum inductance of each inductive sensor 200µH

The total series inductance and shunt capacitance of shield wiring shall be restricted to the following maximum values

Control Relay Terminal No.	Groups		L [mH]	C [µF]	V <sub>OC</sub> [V]	I <sub>SC</sub> [mA]
	A + B	C				
1-2, 2-3	94,8	1,27	↕	↕	↕	↕
4-5, 5-6	299	3,82				
	744	10,2				

Each pair of I.S. wires must be protected by a shield that is grounded at the I.S. Ground. The shield must extend as close to the terminals as possible install per C.E.C. Part 1.





SAMSON AG · MESS- UND REGELTECHNIK  
Weismüllerstraße 3 · 60314 Frankfurt am Main · Germany  
Phone: + 49 69 4009-0 · Fax: +49 69 4009-1507  
Internet: <http://www.samson.de>

**EB 8384-3 EN**

S/Z 2005-01