

# MOUNTING AND OPERATING INSTRUCTIONS



## EB 8257 EN

Translation of original instructions



### **Type 3286 Steam Conditioning Valve · ANSI version**

In combination with an actuator,  
e.g. a Type 3271 or Type 3277 Pneumatic Actuator

Edition November 2023



## Note on these mounting and operating instructions

These mounting and operating instructions assist you in mounting and operating the device safely. The instructions are binding for handling SAMSON devices. The images shown in these instructions are for illustration purposes only. The actual product may vary.

- For the safe and proper use of these instructions, read them carefully and keep them for later reference.
- If you have any questions about these instructions, contact SAMSON's After-sales Service ([aftersaleservice@samsongroup.com](mailto:aftersaleservice@samsongroup.com)).



Documents relating to the device, such as the mounting and operating instructions, are available on our website at [www.samsongroup.com](http://www.samsongroup.com) > **Downloads > Documentation.**

## Definition of signal words

### **DANGER**

*Hazardous situations which, if not avoided, will result in death or serious injury*

### **WARNING**

*Hazardous situations which, if not avoided, could result in death or serious injury*

### **NOTICE**

*Property damage message or malfunction*

### **Note**

*Additional information*

### **Tip**

*Recommended action*

<b>1</b>	<b>Safety instructions and measures</b> .....	<b>1-1</b>
1.1	Notes on possible severe personal injury .....	1-4
1.2	Notes on possible personal injury .....	1-5
1.3	Notes on possible property damage .....	1-7
1.4	Warnings on the device.....	1-8
<b>2</b>	<b>Markings on the device</b> .....	<b>2-1</b>
2.1	Valve nameplate .....	2-1
2.2	Actuator nameplate.....	2-2
2.3	Material identification number .....	2-2
2.4	Label when an adjustable packing is installed .....	2-3
<b>3</b>	<b>Design and principle of operation</b> .....	<b>3-1</b>
3.1	Fail-safe positions .....	3-1
3.2	Versions .....	3-3
3.3	Additional fittings.....	3-3
3.4	Valve accessories .....	3-4
3.5	Technical data .....	3-4
<b>4</b>	<b>Shipment and on-site transport</b> .....	<b>4-1</b>
4.1	Accepting the delivered goods .....	4-1
4.2	Removing the packaging from the valve.....	4-1
4.3	Transporting and lifting the valve.....	4-1
4.3.1	Transporting the valve .....	4-2
4.3.2	Lifting the valve.....	4-3
4.4	Storing the valve .....	4-4
<b>5</b>	<b>Installation</b> .....	<b>5-1</b>
5.1	Installation conditions .....	5-1
5.2	Preparation for installation.....	5-2
5.3	Mounting the device.....	5-3
5.3.1	Mounting the external anti-rotation fixture.....	5-4
5.3.2	Mounting the actuator onto the valve .....	5-13
5.3.3	Installing the valve into the pipeline .....	5-14
5.4	Testing the installed valve.....	5-16
5.4.1	Leak test .....	5-17
5.4.2	Travel motion .....	5-18
5.4.3	Fail-safe position.....	5-18
5.4.4	Pressure test.....	5-18

## Contents

<b>6</b>	<b>Start-up</b> .....	<b>6-1</b>
<b>7</b>	<b>Operation</b> .....	<b>7-1</b>
7.1	Normal operation .....	7-2
7.2	Manual operation .....	7-2
<b>8</b>	<b>Malfunctions</b> .....	<b>8-1</b>
8.1	Troubleshooting .....	8-1
8.2	Emergency action .....	8-3
<b>9</b>	<b>Servicing</b> .....	<b>9-1</b>
9.1	Periodic testing .....	9-3
9.2	Preparing the valve for service work .....	9-5
9.3	Installing the valve after service work.....	9-5
9.4	Service work.....	9-6
9.4.1	Replacing gaskets .....	9-6
9.4.2	Replacing the packing .....	9-8
9.4.3	Replacing the seat and plug.....	9-10
9.4.4	Determining the number of shims required.....	9-12
9.5	Ordering spare parts and operating supplies .....	9-14
<b>10</b>	<b>Decommissioning</b> .....	<b>10-1</b>
<b>11</b>	<b>Removal</b> .....	<b>11-1</b>
11.1	Removing the valve from the pipeline.....	11-2
11.2	Removing the actuator from the valve .....	11-2
<b>12</b>	<b>Repairs</b> .....	<b>12-1</b>
12.1	Returning devices to SAMSON .....	12-1
<b>13</b>	<b>Disposal</b> .....	<b>13-1</b>
<b>14</b>	<b>Certificates</b> .....	<b>14-1</b>
<b>15</b>	<b>Annex</b> .....	<b>15-1</b>
15.1	Tightening torques, lubricants and tools .....	15-1
15.2	Spare parts .....	15-1
15.3	After-sales service .....	15-4

# 1 Safety instructions and measures

## Intended use

The SAMSON Type 3286 Steam Conditioning Valve in combination with an actuator (e.g. Type 3271 or Type 3277 Pneumatic Actuator) is designed to regulate the pressure and temperature of steam. The valve is intended for use in for process engineering applications and thermal plants. The valve with its actuator is designed to operate under exactly defined conditions (e.g. operating pressure, process medium, temperature). Therefore, operators must ensure that the control valve is only used in operating conditions that meet the specifications used for sizing the valve at the ordering stage. In case operators intend to use the control valve in applications or conditions other than those specified, contact SAMSON.

SAMSON does not assume any liability for damage resulting from the failure to use the device for its intended purpose or for damage caused by external forces or any other external factors.

➔ Refer to the technical data and nameplate for limits and fields of application as well as possible uses.

## Reasonably foreseeable misuse

The control valve is not suitable for the following applications:

- Use outside the limits defined during sizing and by the technical data
- Use outside the limits defined by the valve accessories connected to the valve

Furthermore, the following activities do not comply with the intended use:

- Use of non-original spare parts
- Performing service and repair work not described

## Qualifications of operating personnel

The control valve must be mounted, started up, serviced and repaired by fully trained and qualified personnel only; the accepted industry codes and practices must be observed. According to these mounting and operating instructions, trained personnel refers to individuals who are able to judge the work they are assigned to and recognize possible hazards due to their specialized training, their knowledge and experience as well as their knowledge of the applicable standards.

Welding operations are to be performed only by personnel who has the necessary qualification to perform the applied welding procedure and handle the materials used.

## Safety instructions and measures

### Personal protective equipment

We recommend checking the hazards posed by the process medium being used (e.g.

▶ GESTIS (CLP) hazardous substances database). Depending on the process medium and/or the activity, the protective equipment required includes:

- Protective clothing, gloves, eye protection and respiratory protection in applications with hot, cold and/or corrosive media
  - Wear hearing protection when working near the valve
  - Hard hat
  - Safety harness, e.g. when working at height
  - Safety footwear, if applicable ESD (electrostatic discharge) footwear
- ➔ Check with the plant operator for details on further protective equipment.

### Revisions and other modifications

Revisions, conversions or other modifications of the product are not authorized by SAMSON. They are performed at the user's own risk and may lead to safety hazards, for example. Furthermore, the product may no longer meet the requirements for its intended use.

### Safety features

The fail-safe position of the control valve upon air supply or control signal failure depends on the actuator used (see associated actuator documentation). When the valve is combined with a SAMSON Type 3271 or Type 3277 Pneumatic Actuator, the valve moves to a certain fail-safe position (see the 'Design and principle of operation' section) upon supply air or control signal failure. The fail-safe action of the actuator is the same as its direction of action and is specified on the nameplate of SAMSON actuators.

### Warning against residual hazards

To avoid personal injury or property damage, plant operators and operating personnel must prevent hazards that could be caused in the control valve by the process medium, the operating pressure, the signal pressure or by moving parts by taking appropriate precautions. Plant operators and operating personnel must observe all hazard statements, warnings and caution notes in these mounting and operating instructions.

Hazards resulting from the special working conditions at the installation site of the valve must be identified in a risk assessment and prevented through the corresponding safety instructions drawn up by the operator.

### Responsibilities of the operator

Operators are responsible for proper use and compliance with the safety regulations. Operators are obliged to provide these mounting and operating instructions as well as the referenced documents to the operating personnel and to instruct them in proper operation. Furthermore, operators must ensure that operating personnel or third parties are not exposed to any danger.

Operators are additionally responsible for ensuring that the limits for the product defined in the technical data are observed. This also applies to the start-up and shutdown procedures. Start-up and shutdown procedures fall within the scope of the operator's duties and, as such, are not part of these mounting and operating instructions. SAMSON is unable to make any statements about these procedures since the operative details (e.g. differential pressures and temperatures) vary in each individual case and are only known to the operator.

### Responsibilities of operating personnel

Operating personnel must read and understand these mounting and operating instructions as well as the referenced documents and observe the specified hazard statements, warnings and caution notes. Furthermore, operating personnel must be familiar with the applicable health, safety and accident prevention regulations and comply with them.

### Referenced standards, directives and regulations

The control valves comply with the requirements of the European Pressure Equipment Directive 2014/68/EU and Machinery Directive 2006/42/EC.

The 'Certificates' section contains this declaration in compliance with Machinery Directive 2006/42/EC. The declaration in compliance with Pressure Equipment Directive 2014/68/EU is available as a separate document for specific orders.

According to the ignition hazard assessment performed in accordance with Clause 5.2 of ISO 80079-36, the non-electrical control valves do not have their own potential ignition source even in the rare incident of an operating fault. As a result, they do not fall within the scope of Directive 2014/34/EU.

➔ For connection to the equipotential bonding system, observe the requirements specified in Clause 6.4 of EN 60079-14 (VDE 0165-1).

### Referenced documentation

The following documents apply in addition to these mounting and operating instructions:

- Mounting and operating instructions for the mounted actuator, e.g. ► EB 8310-X for the SAMSON Type 3271 or Type 3277 Pneumatic Actuator

## Safety instructions and measures

- Mounting and operating instructions for mounted valve accessories (positioner, solenoid valve etc.)
- ► AB 0100 for tools, tightening torques and lubricant
- Manual ► H 02: Appropriate Machinery Components for SAMSON Pneumatic Control Valves with a Declaration of Conformity of Final Machinery
- When a substance is used in the device, which is listed as being a substance of very high concern on the candidate list of the REACH regulation:  
Information on safe use of the part affected ► [www.samsongroup.com](http://www.samsongroup.com) > About SAMSON > Environment, Social & Governance > Material Compliance
- If a device contains a substance listed as a substance of very high concern on the candidate list of the REACH regulation, this is indicated on the SAMSON delivery note.
- Order-specific declaration of conformity in compliance with Pressure Equipment Directive 2014/68/EU

### 1.1 Notes on possible severe personal injury

#### DANGER

##### **Risk of bursting in pressure equipment.**

Valves and pipelines are pressure equipment. Impermissible pressure or improper opening can lead to valve components bursting.

- ➔ Observe the maximum permissible pressure for valve and plant.
- ➔ Before starting any work on the control valve, depressurize all plant sections affected as well as the valve.
- ➔ Drain the process medium from the plant sections affected as well as from the valve.



## 1.2 Notes on possible personal injury

### WARNING

#### **Risk of burn injuries due to hot or cold components and pipelines.**

Depending on the process medium, valve components and pipelines may get very hot or cold and cause burn injuries.

- Allow components and pipelines to cool down or warm up to the ambient temperature.
- Wear protective clothing and safety gloves.

#### **Risk of hearing loss or deafness due to loud noise.**

The noise emissions depend on the valve version, plant facilities and process medium.

- Wear hearing protection when working near the valve.

#### **Risk of personal injury due to exhaust air being vented.**

While the valve is operating, air is vented from the actuator, e.g. during closed-loop operation or when the valve opens or closes.

- Install the control valve in such a way that vent openings are not located at eye level and the actuator does not vent at eye level in the work position.
- Use suitable mufflers and vent plugs.
- Wear eye protection when working in close proximity to the control valve.

#### **Crush hazard arising from moving parts.**

The control valve contains moving parts (actuator and plug stem), which can injure hands or fingers if inserted into the valve.

- Do not insert hands or finger into the yoke while the air supply is connected to the actuator.
- Before working on the control valve, disconnect and lock the pneumatic air supply as well as the control signal.
- Do not impede the movement of the actuator and plug stem by inserting objects into the yoke.
- Before unblocking the actuator and plug stem after they have become blocked (e.g. due to seizing up after remaining in the same position for a long time), release any stored energy in the actuator (e.g. spring compression). See associated actuator documentation.

### **WARNING**

#### **Risk of personal injury due to incorrect removal of the anti-rotation fixture under tension.**

Once the actuator has been mounted on the valve and the assembly is ready for use, the clamps of the anti-rotation fixture on the plug stem are under tension.

- Follow the instructions in this document during mounting or removal.
- First remove the actuator from the valve or ensure it cannot transmit any forces to the actuator stem before removing the anti-rotation fixture on the plug stem.

#### **Risk of personal injury due to preloaded springs.**

Valves in combination with pneumatic actuators with preloaded springs are under tension. These control valves with SAMSON pneumatic actuators can be identified by the long bolts protruding from the bottom of the actuator.

- Before starting any work on the actuator, relieve the compression from the preloaded springs (see associated actuator documentation).

#### **For valves fitted with a bellows seal: Risk of personal injury due to pressurized components and process medium being discharged.**

- Do not loosen the screw of the test connection while the valve is pressurized.

#### **Risk of personal injury due to residual process medium in the valve.**

While working on the valve, residual medium can flow out of the valve and, depending on its properties, cause personal injury, e.g. (chemical) burns.

- If possible, drain the process medium from the plant sections affected and from the valve.
- Wear protective clothing, safety gloves, respiratory protection and eye protection.

#### **Exposure to hazardous substances poses a serious risk to health.**

Certain lubricants and cleaning agents are classified as hazardous substances. These substances have a special label and a material safety data sheet (MSDS) issued by the manufacturer.

- Make sure that an MSDS is available for any hazardous substance used. If necessary, contact the manufacturer to obtain an MSDS.
- Inform yourself about the hazardous substances and their correct handling.

**⚠ WARNING**

**Risk of personal injury due to incorrect operation, use or installation as a result of information on the valve being illegible.**

Over time, markings, labels and nameplates on the valve may become covered with dirt or become illegible in some other way. As a result, hazards may go unnoticed and the necessary instructions not followed. There is a risk of personal injury.

- Keep all relevant markings and inscriptions on the device in a constantly legible state.
- Immediately renew damaged, missing or incorrect nameplates or labels.

### 1.3 Notes on possible property damage

**ⓘ NOTICE**

**Risk of valve damage due to contamination (e.g. solid particles) in the pipeline.**

The plant operator is responsible for cleaning the pipelines in the plant.

- Flush the pipelines before start-up.
- Pickle and blow through the steam pipe.

**Risk of valve damage due to unsuitable medium properties.**

The valve is designed for steam and cooling water.

- Make sure that the steam and cooling water are clean and free of mineral components.
- Install strainers.

**Risk of leakage and valve damage due to excessively high or low tightening torques.**

Observe the specified torques when tightening control valve components. Excessive tightening torques lead to parts wearing out more quickly. Parts that are too loose may cause leakage.

- Observe the specified tightening torques (▶ AB 0100).

### ! NOTICE

#### **Risk of valve damage due to the use of unsuitable tools.**

Certain tools are required to work on the valve.

→ Only use tools approved by SAMSON (▶ AB 0100).

#### **Risk of valve damage due to the use of unsuitable lubricants.**

The lubricants to be used depend on the valve material. Unsuitable lubricants may corrode and damage surfaces.

→ Only use lubricants approved by SAMSON (▶ AB 0100).

#### **Risk of the process medium being contaminated through the use of unsuitable lubricants and/or contaminated tools and components.**

→ If necessary, keep the valve and the tools used free from solvents and grease.

→ Make sure that only suitable lubricants are used.

## 1.4 Warnings on the device

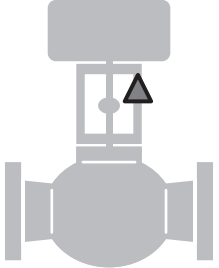
Warning symbols	Meaning of the warning	Location on the device
	<p>Warning against moving parts There is a risk of injury to hands or fingers due to the stroking movement of the actuator and plug stem if they are inserted into the yoke while the air supply is connected to the actuator.</p>	

## 2 Markings on the device

The nameplate shown was up to date at the time of publication of this document. The nameplate on the device may differ from the one shown.

### 2.1 Valve nameplate

The nameplate (80) is affixed to the yoke of the valve (see Fig. 2-1).

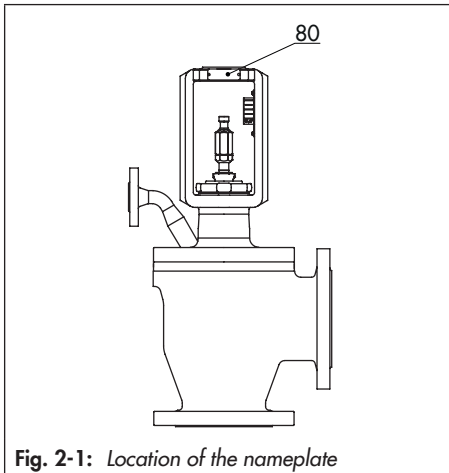

Fig. 2-1: Location of the nameplate

**i Note**

Fig. 2-2 and the inscription table list all possible characteristics and options that may appear on a valve nameplate. Only the inscriptions relevant to the ordered Type 3286 Valve actually appear on the nameplate.

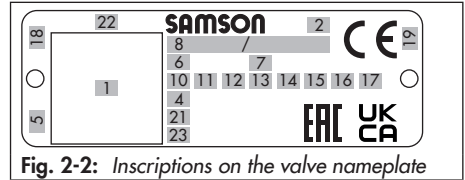

Fig. 2-2: Inscriptions on the valve nameplate

Item	Inscription meaning
1	Data Matrix code
2	Type designation
4	Material
5	Month and year of manufacture
6	Valve size: DIN: <b>DN</b> · ANSI: <b>NPS</b> · JIS: <b>DN</b>
7	Pressure rating: DIN: <b>PN</b> · ANSI: <b>CL</b> · JIS: <b>K</b>
8	Order number/item
10	Flow coefficient: DIN: <b>KVS</b> · ANSI: <b>CV</b>
11	Characteristic: %: equal percentage · <b>LIN</b> : linear <b>mod-lin</b> : modified linear <b>NO/NC</b> : on/off service
12	Seat-plug seal: <b>ME</b> : metal · <b>HA</b> : carbide metal · <b>ST</b> : metal base material with Stellite® facing <b>KE</b> : ceramic · <b>PT</b> : PTFE soft seal · <b>PK</b> : PEEK soft seal
13	Seat code (trim material): on request
14	Pressure balancing: DIN: <b>D</b> · ANSI/JIS: <b>B</b> Version: <b>M</b> : mixing valve · <b>V</b> : diverting valve

## Markings on the device

Item	Inscription meaning
15	Noise reduction: <b>1</b> : flow divider (ST) 1 · <b>2</b> : ST 2 · <b>3</b> : ST 3 · <b>1/PSA</b> : ST 1 standard and integrated in seat for PSA valve · AC-1/AC-2/AC-3/AC-5: anti-cavitation trim, versions 1 to 5 <b>LK</b> : perforated plug · <b>LK1/LK2/LK3</b> : perforated plug with flow divider ST 1 to ST 3 · <b>MHC1</b> : multi-hole cage · <b>CC1</b> : Combi Cage · <b>ZT1</b> : Zero Travel · <b>LDB</b> : Low dB
16	PSA version: <b>PSA</b>
17	Cage/seat style: <b>CS</b> : clamped-in seat · <b>CG</b> : guided cage · <b>SS</b> : screwed-in seat · <b>SF</b> : suspended cage, flanged seat
18	Country of origin
19	ID of the notified body (EU), for example: – <b>0062</b> for Bureau Veritas Services SAS, 8 Cours du Triangle, 92800 PUTEAUX – LA DEFENSE
21	<b>PED</b> : Pressure Equipment Directive <b>G1/G2</b> : gases and vapors Fluid group 1 = hazardous Fluid group 2 = other <b>L1/L2</b> : liquids Fluid group 1 = hazardous Fluid group 2 = other <b>I/II/III</b> : Category 1 to 3
22	Serial number
23	Hardware version (NE 53)

The serial number enables you to view the device's current technical data as configured by SAMSON. The material number enables you to view the device's technical data as configured by SAMSON upon delivery of the device. To view these data, go to our website at ► [www.samsongroup.com](http://www.samsongroup.com) > Products > Electronic nameplate. For example, you can also use the associated information to order a new nameplate from our After-sales Service, if required.

## 2.2 Actuator nameplate

See associated actuator documentation.

## 2.3 Material identification number

The seat and plug of the valves have an item number written on them. You can contact us stating this item number to find out which material is used. Additionally, a seat code is used to identify the trim material. This seat code is specified on the nameplate.



### Tip

We recommend to include the device's serial number (22 on the nameplate) and/or its material number (as specified in the order confirmation) in the plant documentation for the associated tag number.

## 2.4 Label when an adjustable packing is installed

An instructional label is affixed to the valve when an adjustable packing is installed (see Fig. 2-3).







### 3 Design and principle of operation

The single-seated Type 3286 Angle Valve acts as a steam conditioner and is fitted with a flow divider 3. The Type 3286 Steam-conditioning Valve is preferably combined with a SAMSON Type 3271 or Type 3277 Pneumatic Actuator (see Fig. 3-1). It can also be combined with other actuators.

The seat (4), flow divider (62) and plug with plug stem (5) are installed in the body (1). The plug stem is connected to the actuator stem (A7) by the stem connector clamps (A26/27) and is sealed by a spring-loaded V-ring packing (15). Alternatively, an adjustable high-temperature packing can be used.

The springs in the pneumatic actuator are located either above or below the diaphragm (A4) depending on the selected fail-safe action (see section 3.1). A change in the signal pressure acting on the diaphragm causes the plug to move. The actuator size is determined by the diaphragm area.

The medium flows through the valve in the direction indicated by the arrow. A rise in signal pressure causes the force acting on the diaphragm in the actuator to increase. The springs are compressed. Depending on the selected direction of action, the actuator stem retracts or extends. As a result, the plug position in the seat changes and determines the flow rate through the valve and the pressure  $p_2$  as well.

The cooling water is fed to the flow divider (62) through the connecting pipe on the bonnet (2) and holes in the clamping element

(63). After flowing through the cross-sectional area between seat and plug, the steam flow reaches its maximum velocity and comes into contact with the cooling water at the inner wall of the flow divider. The steam flow and the entrained water are mixed in the narrow wire mesh of the flow divider. At the same time, the steam velocity is reduced, releasing some of its heat to the water across the large surface of the wire mesh coil, which causes it to evaporate quickly. The steam/water mixture leaves the flow divider as a fine mist with a high steam content. Evaporation is completed a short distance downstream of the steam conditioning valve. The water atomization described is ensured over the whole load range since the steam velocity at the throttling point is independent of the flow rate.

#### 3.1 Fail-safe positions

The fail-safe position of the control valve upon air supply or control signal failure depends on the actuator used (see associated actuator documentation).

Depending on how the compression springs are arranged in the SAMSON Type 3271 and Type 3277 Pneumatic Actuator, the valve has one of two different fail-safe positions:

##### Actuator stem extends (FA)

When the signal pressure is reduced or the air supply fails, the springs move the actuator stem downward and close the valve. The valve opens when the signal pressure is in-

## Design and principle of operation

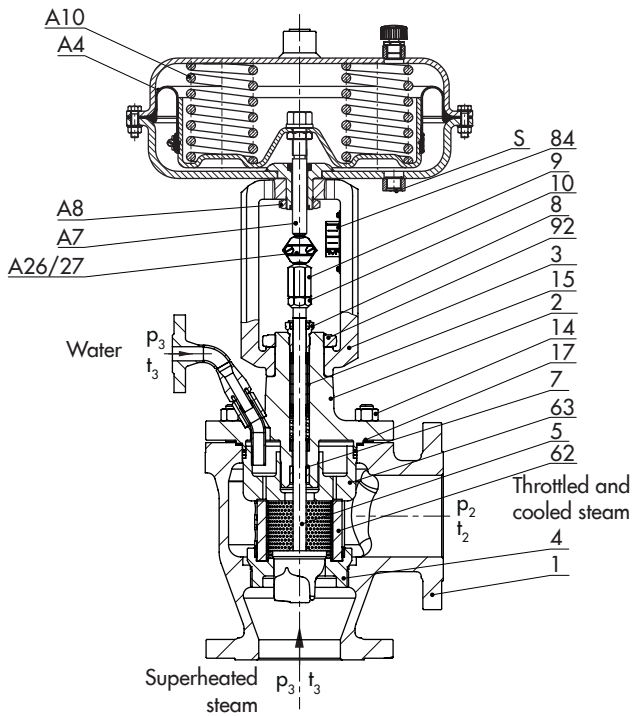

1	Body	17	Body gasket
2	Bonnet (with connecting pipe)	62	Flow divider ST 3
3	Yoke	63	Clamping element
4	Seat	84	Travel indicator scale
5	Plug (with plug stem)	92	Castellated nut
7	Guide bushing	A4	Diaphragm
8	Threaded bushing (packing nut)	A7	Actuator stem
9	Stem connector nut	A8	Ring nut
10	Lock nut	A10	Spring
14	Body nut	A26/27	Stem connector clamps
15	Packing	S	Signal pressure connection

**Fig. 3-1:** Type 3286 Valve with Type 3271 Pneumatic Actuator

creased enough to overcome the force exerted by the springs.

### Actuator stem retracts (FE)

When the signal pressure is reduced or the air supply fails, the springs move the actuator stem upwards and open the valve. The valve closes when the signal pressure is increased enough to overcome the force exerted by the springs.



#### Tip

*The actuator's direction of action can be reversed, if required. Refer to the mounting and operating instructions of the pneumatic actuator:*

► EB 8310-X for Type 3271 and Type 3277

## 3.2 Versions

### With insulating section/bellows seal

The modular design allows an insulating section or bellows seal to be fitted to the standard valve version.

### Actuators

In these instructions, the preferable combination with a SAMSON Type 3271 or Type 3277 Pneumatic Actuator is described. The pneumatic actuator (with or without handwheel) can be replaced by another pneumatic actuator in a different size, but with the same travel.

→ Observe the maximum permissible actuator force.

### **i** Note

*If the travel range of the actuator is larger than the travel range of the valve, the spring assembly in the actuator must be preloaded so that the travel ranges match. See associated actuator documentation.*

The basic pneumatic actuator can be replaced by a pneumatic actuator with additional handwheel or by an electric actuator (see Information Sheet ► T 8300).

## 3.3 Additional fittings

### Steam trap

Automatic steam traps must be installed at the lowest point in the upstream and downstream lines to ensure proper functioning of the plant.

### Check valve

We recommend installing check valves between the steam conditioning valve and the cooling water valve to protect the condensate system.

### Strainers

We recommend installing a SAMSON strainer upstream of the valve body and in the inlet pipe for the water supply. It prevents solid particles in the process medium from damaging the valve.

### Bypass and shut-off valves

We recommend installing a shut-off valve both upstream of the strainer and downstream of the valve and installing a bypass line. The bypass ensures that the plant does

## Design and principle of operation

not need to be shut down for service and repair work on the valve.

### Insulation

Control valves can be insulated to reduce heat energy transfer. Refer to the instructions in the 'Installation' section.

### Test connection

Versions with bellows seal fitted with a test connection (G 1/8) at the top bellows bonnet allow the sealing ability of the bellows to be monitored.

Particularly for liquids and vapors, we recommend installing a suitable leakage indicator (e.g. a contact pressure gauge, an outlet to an open vessel or an inspection glass).

### Safety guard

For operating conditions that require increased safety (e.g. in cases where the valve is freely accessible to untrained staff), a safety guard must be installed to rule out a crush hazard arising from moving parts (actuator and plug stem). Plant operators are responsible for deciding whether a guard is to be used. The decision is based on the risk posed by the plant and its operating conditions.

### Noise reduction

A further noise reduction can only be achieved by using additional insulation as the steam conditioning valve is already equipped with flow divider 3.

## 3.4 Valve accessories

Information Sheet ► T 8350

Depending on the excessive heat that radiates from the steam conditioning valve, only mount valve accessories (e.g. positioners) on the inlet side of the cooling water valve.

## 3.5 Technical data

The nameplates on the valve and actuator provide information on the control valve version. See the 'Markings on the device' section.

---

### **i** Note

*More information is available in Data Sheet ► T 8257.*

---

### Noise emissions

SAMSON is unable to make general statements about noise emissions. The noise emissions depend on the valve version, plant facilities and process medium.

**Table 3-1:** Technical data for Type 3286

Material		Cast steel · A216 WCC	Cast steel · A217 WC6
Valve size	NPS	2...12	
Pressure rating	Class	150...900	
Type of connection	Flanges	ASME B16.5	
	Welding ends	ASME B16.25	
Seat-plug seal		Metal seal or high-performance metal seal	
Characteristic		Equal percentage or linear	
Rangeability		50:1	
Conformity		CE · EAC	
<b>Temperature ranges</b> · Permissible operating pressures acc. to pressure-temperature diagrams (see Information Sheet ▶ T 8000-2)			
Body without insulating section		14 to 428 °F (-10 to +220 °C) · Up to 660 °F (up to 350 °C) with high-temperature packing	
Body with	Insulating section	-20 to +800 °F (-29 to +425 °C)	-20 to +932 °F (-29 to +500 °C)
Valve plug	Standard	Metal seal -20 to +932 °F (-29 to 500 °C)	
	Balanced with PTFE	-20 to +428 °F (-29 to +220 °C)	
	Balanced with graphite ring	-20 to +932 °F (-29 to +500 °C)	
<b>Leakage class</b> according to ANSI/FCI 70-2			
Valve plug	Standard	Metal seal	IV
		High-performance metal seal	V
	Balanced with PTFE	Standard: IV · High-performance metal seal: V	
	Balanced with graphite ring	IV	

**Dimensions and weights**

Table 3-2 and Table 3-3 provide an overview of the dimensions and weights of the standard version of Type 3286 Valve. The lengths and heights in the dimensional drawings are shown on page 3-6.

Dimensions (in inch and mm) and weights (in lbs and kg)

## Design and principle of operation

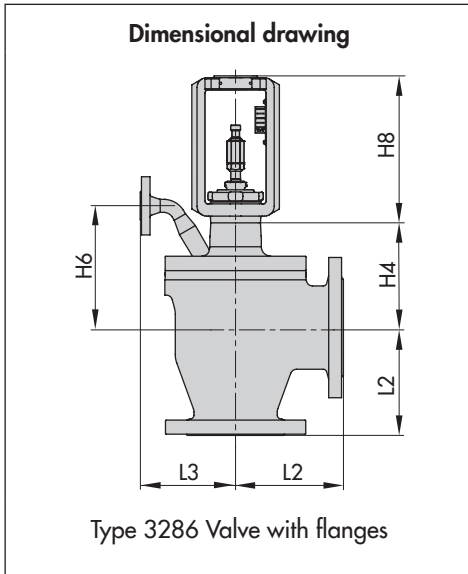

### **i Note**

The dimensions H6 and L3 for the cooling water connection are available on request. Refer to the following data sheets for more dimensions and weights:

▶ T 8257 for valves with bellows seal or insulating section

The associated actuator documentation applies to actuators, e.g. SAMSON pneumatic actuators:

▶ T 8310-1 for Type 3271 or Type 3277 Pneumatic Actuators up to 750 cm<sup>2</sup> actuator area

▶ T 8310-2 for Type 3271 Actuator with 1000 cm<sup>2</sup> actuator area and larger

▶ T 8310-3 for Type 3271 Actuator with 1400-60 cm<sup>2</sup> actuator area

**Table 3-2:** Dimensions for Type 3286 Valve · Face-to-face dimensions according to ANSI/ISA-75.08.01 for Class 600 and lower and according to ASME B16.10 for Class 900 and higher

Valve	NPS DN	2	3	4	6	8	10	12
		50	80	100	150	200	250	300
Length L2	Class 150	in	5.00	5.88	6.94	8.88	10.69	On request
		mm	127	149	176	226	272	
	Class 300	in	5.25	6.25	7.25	9.31	11.19	
		mm	133	159	184	236	284	
	Class 600	in	5.62	6.62	7.75	10.00	12.00	
		mm	143	168	197	254	305	
	Class 900	in	7.25	7.50	9.00	12.00	14.50	
		mm	184	190	229	305	368	
Height H4	Class 150 to 600	in	6.89	6.30	6.69	9.13	On request	
		mm	175	160	170	210		
	Class 900	in	8.70	6.30	6.69	9.13		
		mm	221	160	170	210		

Valve	NPS		2	3	4	6	8	10	12	
	DN		50	80	100	150	200	250	300	
H8 for actuator	350 cm <sup>2</sup>	in	9.45	9.45	9.45	-				
		mm	240	240	240					
	355 cm <sup>2</sup>	in	9.45	9.45	9.45	16.46	-			
		mm	240	240	240	418				
	700 cm <sup>2</sup>	in	9.45	9.45	9.45	16.46	16.46	-		
		mm	240	240	240	418	418			
	750 cm <sup>2</sup>	in	9.45	9.45	9.45	16.46	16.46	16.46	-	
		mm	240	240	240	418	418	418		
	1000 cm <sup>2</sup>	in	11.61	11.61	11.61	16.46	16.46	-		
		mm	295	295	295	418	418			
	1400-60 cm <sup>2</sup>	in	11.61	11.61	11.61	16.46	16.46	19.81	19.81	
		mm	295	295	295	418	418	503	503	
	1400-120 cm <sup>2</sup>	in	18.90	18.90	18.90	19.81	19.81	19.81	19.81	
		mm	480	480	480	503	503	503	503	
	2800 cm <sup>2</sup>	in	18.90	18.90	18.90	19.81	19.81	25.60	25.60	
		mm	480	480	480	503	503	650	650	
2 x 2800 cm <sup>2</sup>	in	18.90	18.90	18.90	19.81	19.81	19.81 <sup>1)</sup>	25.60		
	mm	480	480	480	503	503	503 <sup>1)</sup>	650		

1) H8 = 25.60" (650 mm) with 9.84" (250 mm) seat bore

**Table 3-3: Weights for Type 3286**

Valve	NPS		2	3	4	6	8	10	12	
	DN		50	80	100	150	200	250	300	
Valve without actuator	Class 150	lbs	66	110	152	342	948	1892	2028	
		kg	30	50	69	155	460	858	920	
	Class 300	lbs	95	170	247	694	948	1892	2028	
		kg	43	77	112	315	430	858	920	
	Class 600	lbs	95	170	247	694	1096	2509	2535	
		kg	43	77	112	315	497	1138	1150	
	Class 900	lbs	95	170	247	694	1157	2844	3263	
		kg	43	77	112	315	525	1290	1480	





## 4 Shipment and on-site transport

The work described in this section is only to be performed by personnel appropriately qualified to carry out such tasks.

### 4.1 Accepting the delivered goods

After receiving the shipment, proceed as follows:

1. Check the scope of delivery. Check that the specifications on the valve nameplate match the specifications in the delivery note. See the 'Markings on the device' section for nameplate details.
2. Check the shipment for transportation damage. Report any damage to SAMSON and the forwarding agent (refer to delivery note).
3. Determine the weight and dimensions of the units to be lifted and transported in order to select the appropriate lifting equipment and lifting accessories. Refer to the transport documents and the 'Technical data' section.

### 4.2 Removing the packaging from the valve

Observe the following sequence:

- Do not open or remove the packaging until immediately before lifting to install the valve into the pipeline.

- Leave the control valve in its transport container or on the pallet to transport it on site.
- Do not remove the protective caps from the inlet and outlet until immediately before installing the valve into the pipeline. They prevent foreign particles from entering the valve.
- Dispose and recycle the packaging in accordance with the local regulations.

### 4.3 Transporting and lifting the valve

---

#### **⚠ DANGER**

***Danger due to suspended loads falling.***

- *Stay clear of suspended or moving loads.*
  - *Close off and secure the transport paths.*
- 

#### **⚠ WARNING**

***Risk of lifting equipment tipping over and risk of damage to lifting accessories due to exceeding the rated lifting capacity.***

- *Only use approved lifting equipment and accessories whose minimum lifting capacity is higher than the weight of the valve (including actuator and packaging, if applicable).*
-

### **WARNING**

**Risk of personal injury due to the control valve tipping over.**

- Observe the valve's center of gravity.
- Secure the valve against tipping over or turning.

### **NOTICE**

**Risk of valve damage due to incorrectly attached slings.**

The lifting eyelet/eyebolt on SAMSON actuators is only intended for mounting and removing the actuator as well as lifting the actuator without valve. Do not use this lashing point to lift the entire control valve assembly.

- When lifting the control valve, make sure that the slings attached to the valve body bear the entire load.
- Do not attach load-bearing slings to the actuator, handwheel or cooling water connection.
- Observe lifting instructions (see section 4.3.2).

### **Tip**

A swivel hoist can be screwed into SAMSON actuators with a female thread on the top diaphragm case in place of the eyebolt (see associated actuator documentation).

In contrast to the lifting eyelet/eyebolt, the swivel hoist is designed for setting a control valve assembly upright.

The sling between the swivel hoist and rigging equipment (hook, shackle etc.) must not bear any load when lifting a control valve

assembly. The sling only protects the control valve from tilting while being lifted.

### **Tip**

Our after-sales service can provide more detailed transport and lifting instructions on request.

## 4.3.1 Transporting the valve

The control valve can be transported using lifting equipment (e.g. crane or forklift).

- Leave the control valve in its transport container or on the pallet to transport it.
- Observe the transport instructions.

### **Transport instructions**

- Protect the control valve against external influences (e.g. impact).
- Do not damage the corrosion protection (paint, surface coatings). Repair any damage immediately.
- Protect the piping and any mounted valve accessories against damage.
- Protect the control valve against moisture and dirt.
- The permissible transportation temperature of standard control valves is  $-20$  to  $+65$  °C ( $-4$  to  $+149$  °F).

### **Note**

Contact our after-sales service for the transportation temperatures of other valve versions.

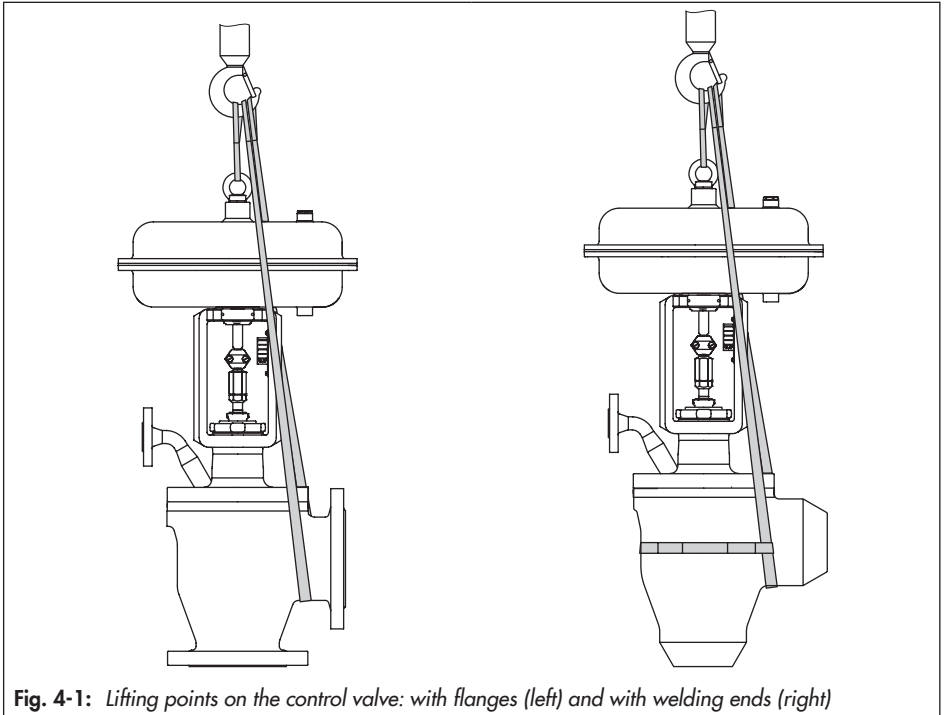

Fig. 4-1: Lifting points on the control valve: with flanges (left) and with welding ends (right)

### 4.3.2 Lifting the valve

To install a large valve into the pipeline, use lifting equipment (e.g. crane or forklift) to lift it.

#### Lifting instructions

- Use a hook with safety latch (see Fig. 4-1) to secure the slings from slipping off the hook during lifting and transporting.
- Secure slings against slipping.
- Make sure the slings can be removed from the valve once it has been installed into the pipeline.
- Prevent the control valve from tilting or tipping over.
- Do not leave loads suspended when interrupting work for longer periods of time.
- Make sure that the axis of the pipeline is always horizontal during lifting and the axis of the plug stem is always vertical.
- Make sure that the additional sling between the lashing point on the actuator

## Shipment and on-site transport

and rigging equipment (hook, shackle etc.) does not bear any load when lifting valves larger than NPS 6. The sling only protects the control valve from tilting while being lifted. Before lifting the control valve, tighten the sling.

- Make sure that the cooling water connection on the bonnet is not bent by the slings.

### a) Version with flanges

1. Attach one sling to each flange of the body and to the rigging equipment (e.g. hook) of the crane or forklift (see Fig. 4-1).
2. **NPS 6 and larger:** attach another sling to the lashing point on the actuator and to the rigging equipment.
3. Carefully lift the control valve. Check whether the lifting equipment and accessories can bear the weight.
4. Move the control valve at an even pace to the site of installation.
5. Install the valve into the pipeline (see the 'Installation' section).
6. After installation in the pipeline, check whether the flanges are bolted tight and the valve in the pipeline holds.
7. Remove slings.

### b) Version with welding ends

1. Attach one sling to each welding end of the body and to the rigging equipment (e.g. hook) of the crane or forklift (see Fig. 4-1).
2. Secure the slings attached to the body against slipping using a connector.
3. **NPS 6 and larger:** attach another sling to the lashing point on the actuator and to the rigging equipment.
4. Carefully lift the control valve. Check whether the lifting equipment and accessories can bear the weight.
5. Move the control valve at an even pace to the site of installation.
6. Install the valve into the pipeline (see the 'Installation' section).
7. After installation, check whether the weld seams hold.
8. Remove slings.

## 4.4 Storing the valve

---

### ⓘ NOTICE

**Risk of valve damage due to improper storage.**

- Observe the storage instructions.
  - Avoid long storage times.
  - Contact SAMSON in case of different storage conditions or longer storage times.
-

---

**i Note**

*We recommend regularly checking the control valve and the prevailing storage conditions during long storage periods.*

---

**Storage instructions**

- Protect the control valve against external influences (e.g. impact).
- Secure the valve in the stored position against slipping or tipping over.
- Do not damage the corrosion protection (paint, surface coatings). Repair any damage immediately.
- Protect the control valve against moisture and dirt. Store it at a relative humidity of less than 75 %. In damp spaces, prevent condensation. If necessary, use a drying agent or heating.
- Make sure that the ambient air is free of acids or other corrosive media.
- The permissible storage temperature of standard control valves is  $-20$  to  $+65$  °C ( $-4$  to  $+149$  °F). Contact our after-sales service for the storage temperatures of other valve versions.
- Do not place any objects on the control valve.

**Special storage instructions for elastomers**

Elastomer, e.g. actuator diaphragm

- To keep elastomers in shape and to prevent cracking, do not bend them or hang them up.
- We recommend a storage temperature of  $15$  °C ( $59$  °F) for elastomers.

- Store elastomers away from lubricants, chemicals, solutions and fuels.

---

**💡 Tip**

*SAMSON's After-sales Service can provide more detailed storage instructions on request.*

---



## 5 Installation

The work described in this section is only to be performed by personnel appropriately qualified to carry out such tasks.

### 5.1 Installation conditions

#### Work position

The work position for the control valve is the front view looking onto the operating controls (including valve accessories).

Plant operators must ensure that, after installation of the device, the operating personnel can perform all necessary work safely and easily access the device from the work position.

#### Pipeline routing

To ensure the control valve functions properly, follow the installation instructions given below:

- ➔ To determine the required inlet and outlet lengths as well as how the pipeline is to be routed, contact SAMSON.
- ➔ Install the valve free of stress and with the least amount of vibrations as possible. Read information under 'Mounting position' and 'Support or suspension' in this section.
- ➔ Install the valve allowing sufficient space to remove the actuator and valve or to perform service and repair work on them.



**Tip**

Fig. 5-1 shows a sample assembly of a steam pressure/temperature control with steam conditioner.

#### Mounting position

The control valve must always be installed with the actuator upright on top.

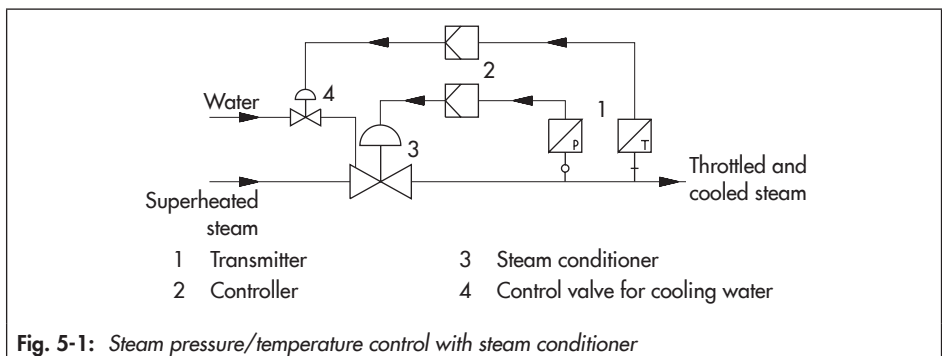

### Support or suspension

---

#### **i** Note

*The plant engineering company is responsible for selecting and implementing a suitable support or suspension of the installed control valve and the pipeline.*

---

Depending on the valve version and mounting position, the valve, actuator and pipeline must be supported or suspended.

### Flanges

- The flanges of the cooling water valve as well as the inlet and outlet flanges of the steam conditioning valve must be designed for the same pressure rating.
- To facilitate the separation of the steam conditioning valve and cooling water valve for repair and servicing work, a flange must be used to connect the cooling water valve to the steam conditioning valve. If necessary, fit a blind flange.

### Temperature sensor

- Install a temperature sensor at least 10 m downstream of the valve.

#### **i** Note

*The exact distance is determined at the valve sizing stage based on the operating data.*

---

### Valve accessories

If excessive heat radiates from the steam conditioning valve, only mount valve accessories (e.g. positioners) on the inlet side of the cooling water valve.

- During connection of valve accessories, make sure that they are easily accessible and can be operated safely from the work position.

### Vent plugs

Vent plugs are screwed into the exhaust air ports of pneumatic and electropneumatic devices. They ensure that any exhaust air that forms can be vented to the atmosphere (to avoid excess pressure in the device). Furthermore, the vent plugs allow air intake to prevent a vacuum from forming in the device.

- Locate the vent plug on the opposite side to the work position of operating personnel.

## 5.2 Preparation for installation

Before installation, make sure the following conditions are met:

- The valve is clean.
- The valve and all valve accessories (including piping) are not damaged.
- The valve data on the nameplate (type designation, valve size, material, pressure rating and temperature range) match the plant conditions (size and pressure rating of the pipeline, medium temperature etc.). See the 'Markings on the device' section for nameplate details.
- The requested or required additional pipe fittings (see 'Additional fittings' in the 'Design and principle of operation' section) have been installed or prepared as necessary before installing the valve.



**! NOTICE**

**Risk of control valve damage due to incorrect insulation.**

- Only insulate control valves with insulating section or bellows seal up to the bonnet flange of the valve body for medium temperatures below 0 °C (32 °F) and above 220 °C (428 °F). If the insulating section is insulated, it will not function properly.

Proceed as follows:

- Lay out the necessary material and tools to have them ready during installation work.
- Flush the pipelines.

**i Note**

The plant operator is responsible for cleaning the pipelines in the plant.

- Pickle and blow through the steam pipe.
- For steam applications, dry the pipelines. Moisture will damage the inside of the valve.
- Check any mounted pressure gauges to make sure they function properly.
- When the valve and actuator are already assembled, check the tightening torques of the bolted joints (▶ AB 0100). Components may loosen during transport.

## 5.3 Mounting the device

The activities listed below are necessary to install the valve and before it can be started up.

**! NOTICE**

**Risk of valve damage due to excessively high or low tightening torques.**

Observe the specified torques when tightening control valve components. Excessive tightening torques lead to parts wearing out more quickly. Parts that are too loose may cause leakage.

- Observe the specified tightening torques (▶ AB 0100).

**! NOTICE**

**Risk of valve damage due to the use of unsuitable tools.**

- Only use tools approved by SAMSON (▶ AB 0100).

### 5.3.1 Mounting the external anti-rotation fixture

Before mounting the actuator, the external anti-rotation fixture must be mounted onto the plug stem in some cases. The valve must be closed beforehand.

For SAMSON Type 3271 and Type 3277 Actuators with Type 3273 Hand-operated Actuator, observe the mounting and operating instructions of the hand-operated actuator (handwheel) to mount the anti-rotation fixture ► EB 8312-X.

#### a) Standard version for Series 280 Valves, NPS 6 and larger

See Fig. 5-2 and Fig. 5-3

1. Insert ball bearings (310) into the recesses in the bonnet.
2. Place the yoke (3) on the bonnet in such a way that the ball bearings fit into the recesses of the yoke.
3. Fasten the yoke (3) using the castellated nut (92).
4. Fasten the hanger (83) and warning label (255), if applicable, to the yoke using the screws (82).
5. Position the travel indicator scale (84) on the hanger (83) with the screws (85) according to Table 5-3.
6. Use a soft-faced hammer or lever press to press the sliding washers (309) with their beveled part first (without using any lubricant) into the recesses of the clamps

(301) as far as they will go. Remove any excess material.

7. Apply a thin film of lubricant (114) to the threads of the stem (9) and screws (303).

**NOTICE**

**Impaired functioning due to incorrectly applied lubricant.**

→ Do not apply any lubricant to the threads of the clamps (301) or the plug stem.

8. Position the clamps (301) and stem (9) on the plug stem according to Table 5-3 and tighten screws (303) and washers (304) by hand.
9. Mount the actuator. See section 5.3.2.
10. Thread the stem (9) upwards until the head of the stem rests on the extended actuator stem.
11. Retract the actuator stem to relieve the stem (9).
12. Gradually tighten the screws (303) in a crisscross pattern. Observe the tightening torques specified in Table 5-1.

**Table 5-1: Tightening torques**

Screw size	Tightening torque [Nm]
M12	50
M16	121

13. Check and ensure the following:
  - There is a nominal clearance of 0.5 to 1 mm between the sliding washers and their contact surface on the yoke

on each side (see detailed view Y in Fig. 5-3).

- The anti-rotation fixture does not get stuck on the yoke and can move freely in the direction of travel.

14. Extend the actuator stem again and mount the stem connector clamps.

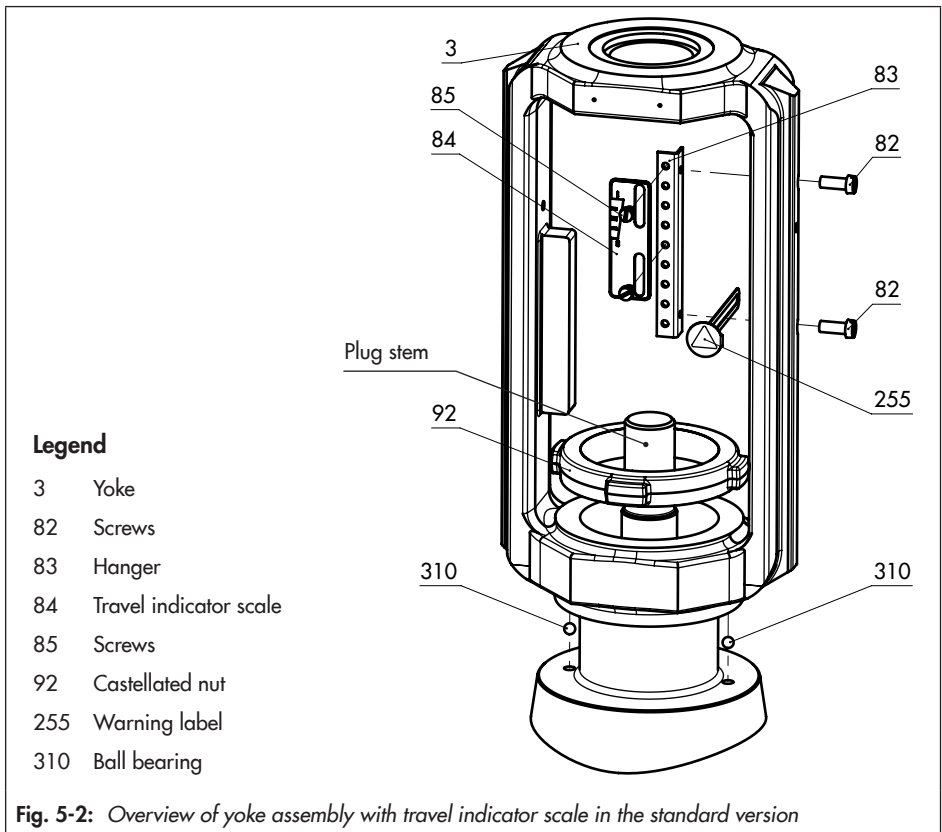

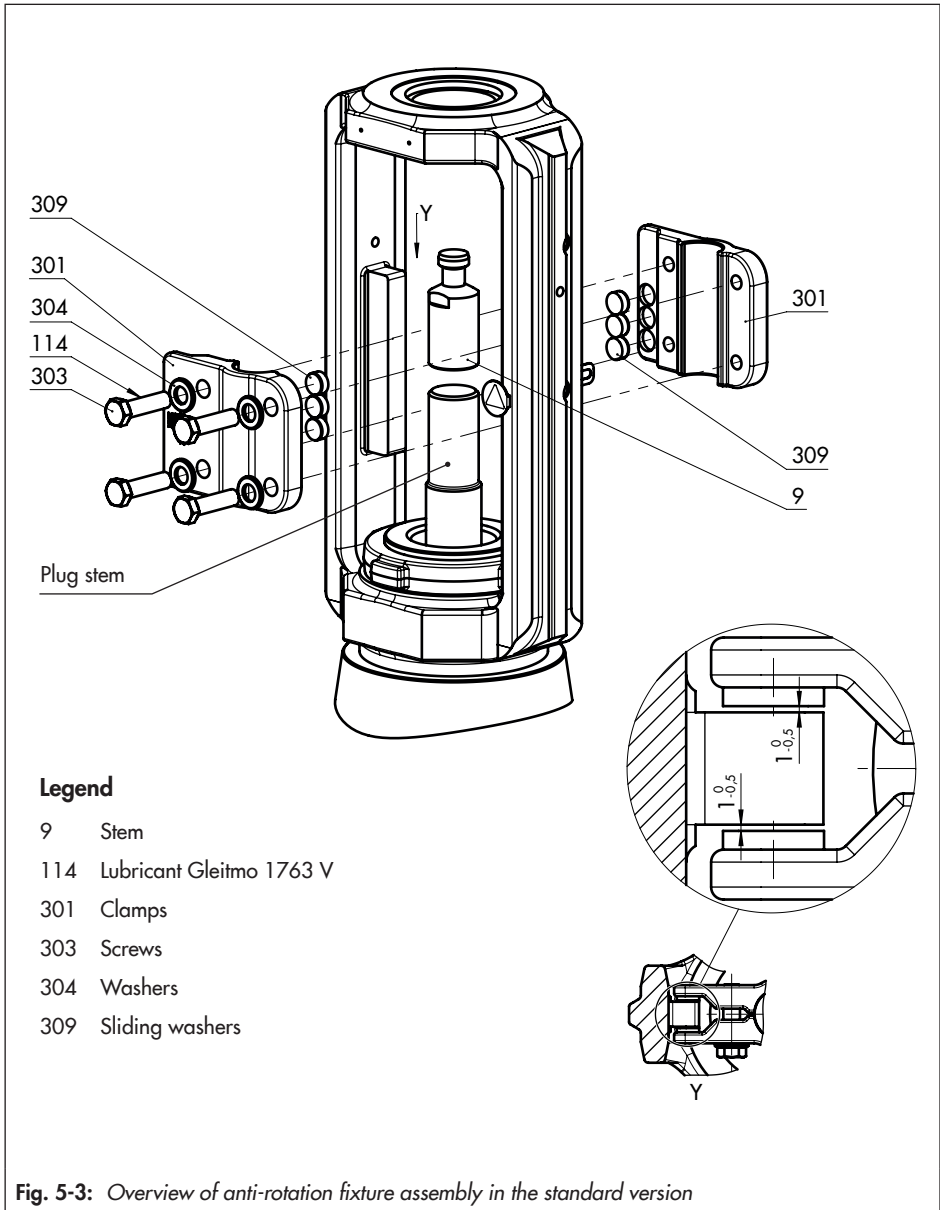

Fig. 5-3: Overview of anti-rotation fixture assembly in the standard version

## b) Special version for Series 280 Valves, NPS 2 to 4

See Fig. 5-4 and Fig. 5-5

1. Fasten the travel indicator scale (84) with hanger (83) and warning label (255), if applicable, to the yoke using the screws (82). While fastening it, position the travel indicator scale (84) on the hanger (83) according to Table 5-3.
2. Screw tight the holder (302) using the screws (306) and washers (308). Observe the tightening torques specified in Table 5-2.
3. Fasten the yoke (3) using the castellated nut (92).
4. Use a soft-faced hammer or lever press to press the sliding washers (309) (without using any lubricant) into the holes of the clamps (301) as far as they will go. Remove any excess material.
5. Apply a thin film of lubricant (114) to the threads of the stem (9) and screws (303).

### NOTICE

**Impaired functioning due to incorrectly applied lubricant.**

→ Do not apply any lubricant to the threads of the clamps (301) or the plug stem.

6. Position the clamps (301) and stem (9) on the plug stem according to Table 5-3 and tighten screws (303) and washers (304) by hand.
7. Mount the actuator. See section 5.3.2.

8. Thread the stem (9) upwards until the head of the stem rests on the extended actuator stem.
9. Retract the actuator stem to relieve the stem (9).
10. Gradually tighten the screws (303) in a crisscross pattern. Observe the tightening torques specified in Table 5-2.

**Table 5-2: Tightening torques**

Item	Screw size	Tightening torque [Nm]
306	M10	30
303	M8	15

11. Check and ensure the following:
  - There is a nominal clearance of 0.5 to 1 mm between the sliding washers and their contact surface on the yoke on each side (see detailed view Y in Fig. 5-5).
  - The anti-rotation fixture does not get stuck on the yoke and can move freely in the direction of travel.
12. Extend the actuator stem again and mount the stem connector clamps.

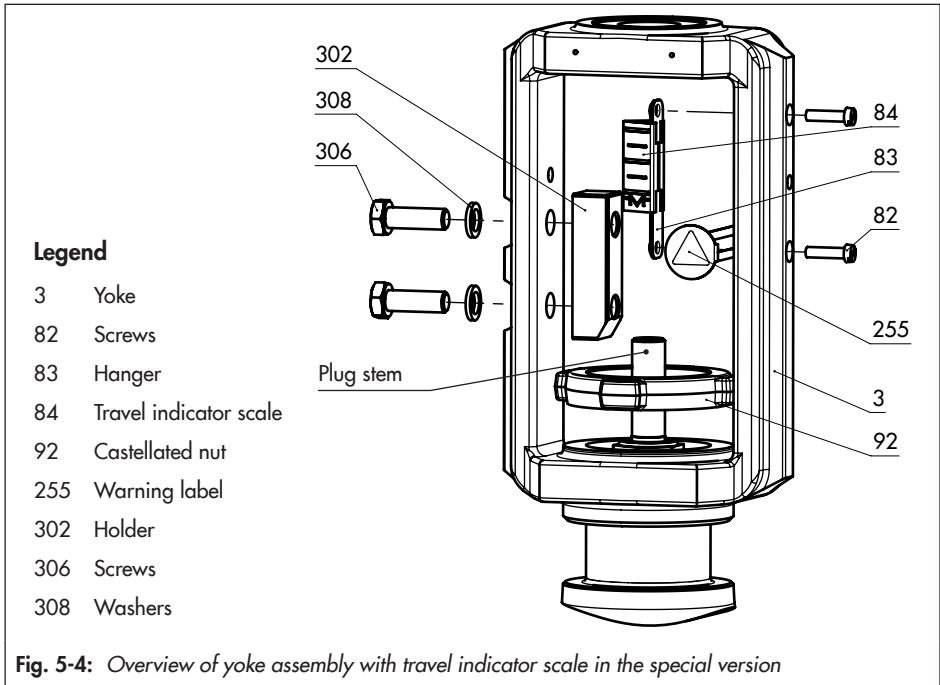

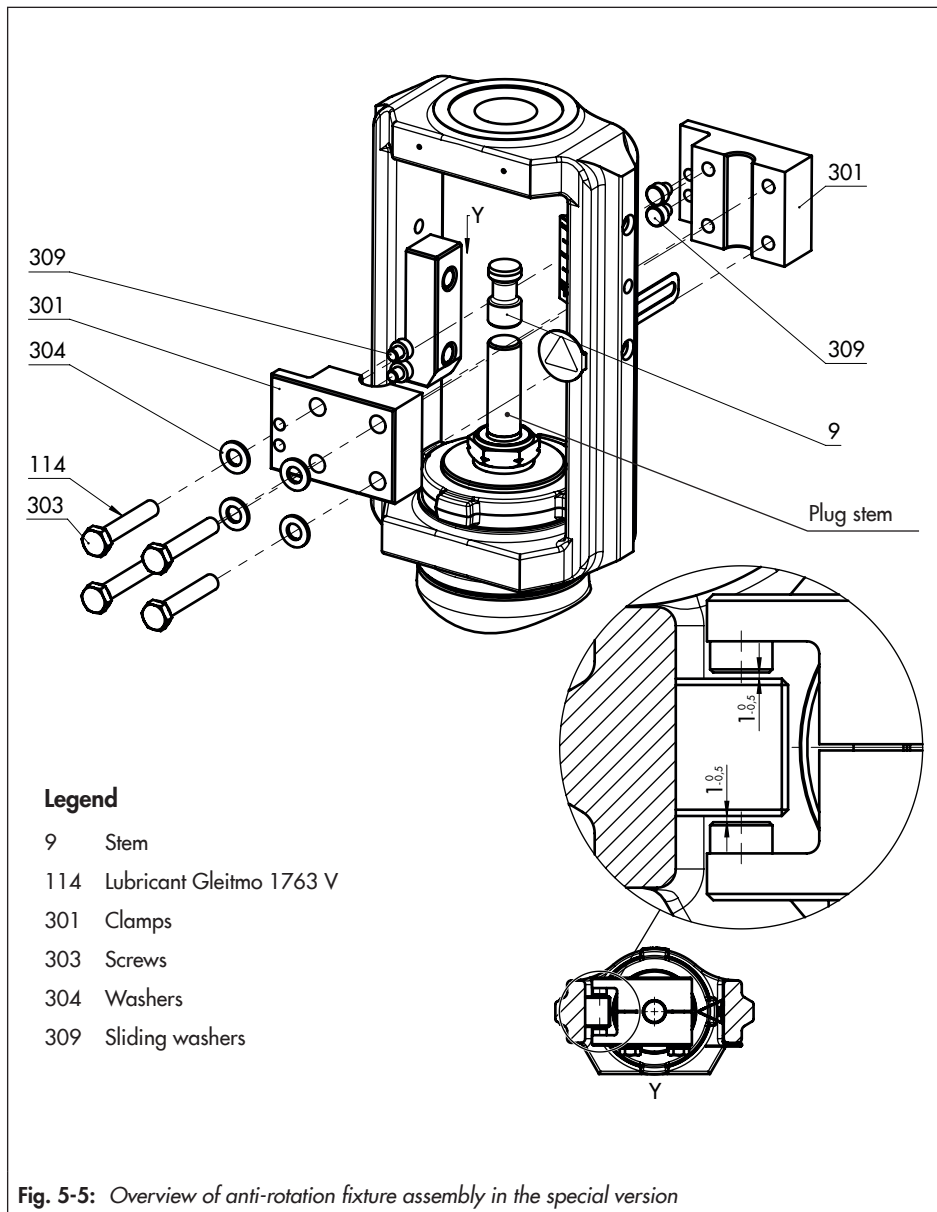

## Installation

**Table 5-3:** Mounting dimensions for Types 3271 and 3277 Pneumatic Actuators · See Fig. 5-6 for dimensional drawing

Actuator [cm <sup>2</sup> ]	Travel [mm]	Actuator preloading		Dimension when the valve is closed [mm]									
		[%]	[mm]	H <sub>F</sub>	H <sub>G</sub>	H <sub>I</sub>	H <sub>K</sub>	H <sub>L</sub>	H <sub>N</sub>	H <sub>O</sub>	H <sub>T</sub>		
<b>DN 50 to 100/NPS 2 to 4 · Special version</b>													
350	15	0	0	111	75	192	54	-	66	42	-		
	15	25	3.75	115	71								
355 700 750	15	50	15	111	75								
	15	75	22.5	118.5	67.5								
	30	0	0	96	90							34.5	30
	30	25	7.5	103.5	82.5							34.5	30
1000 1400-60	15	100	60	136	105			-	-				
	30	75	45	121	120								
1400-120	30	75	90	231	195			-	-				
2800	30	100	120	231	195			-	-				
<b>DN 125 to 150/NPS 6 · Standard version</b>													
355 700 750	15	0	0	263.5	67.5			192	87	48	105	70	145
	15	50	15	256	75	145							
	15	75	22.5	263.5	67.5	145							
	30	0	0	241	90	120							
	30	25	7.5	248.5	82.5	120							
	1000 1400-60	15	100	60	226	105	103						
30		0	0	211	120	88							
30		75	45	211	120	88							
60		0	0	166	165	58							
60		25	15	181	150	58							
1400-120		15	87.5	105	236	180	63						105
	30	0	0	191	225	48	75						
	30	75	90	221	195		105						
	60	0	0	191	225		75						
	60	50	60	191	225		75						
	2800 5600	30	0	0	191		225			75			
30		100	120	221	195		105						
60		0	0	191	225	75							
60		75	90	191	225	75							



Actuator [cm <sup>2</sup> ]	Travel [mm]	Actuator preloading		Dimension when the valve is closed [mm]												
		[%]	[mm]	H <sub>F</sub>	H <sub>G</sub>	H <sub>I</sub>	H <sub>K</sub>	H <sub>L</sub>	H <sub>N</sub>	H <sub>O</sub>	H <sub>T</sub>					
<b>DN 200 to 250/NPS 8 to 10 up to seat bore 200 · Standard version</b>																
355 700 750	30	0	0	241	90	195	87	61	108	65	120					
1000 1400-60	30	0	0	211	120						66	83				
	30	75	45	211	120						66	83				
	60	0	0	166	165						52	55				
	60	25	15	181	150						52	55				
1400-120	15	87.5	105	236	180						61	115				
	30	0	0	191	225						48	76				
	30	75	90	221	195						61	100				
	60	0	0	308	255						61	185				
2800 5600	60	50	60	191	225						48	76				
	30	0	0	191	225						48	76				
	30	100	120	221	195						61	100				
	60	0	0	308	255						61	185				
	60	75	90	191	225						48	76				
<b>DN 250/NPS 10, seat bore 250 and DN 300 to 500/NPS 12 to 20 · Standard version</b>																
1000 1400-60	30	0	0	281	135						237	87	100	150	110	121
	30	75	45	296	120	135										
	60	0	0	251	165	91										
	60	25	15	266	150	91										
1400-120	60	0	0	308	255	145										
	60	50	60	338	225	175										
	120	0	0	278	285	FA <sup>1)</sup> = 115 FE <sup>2)</sup> = 86										
2800 5600	60	0	0	308	255	145										
	60	75	90	338	225	175										
	120	0	0	248	315	FE <sup>2)</sup> = 86										
	120	25	30	278	285	115										

1) FA = Actuator stem extends (fail-close)

2) FE = Actuator stem retracts (fail-open)

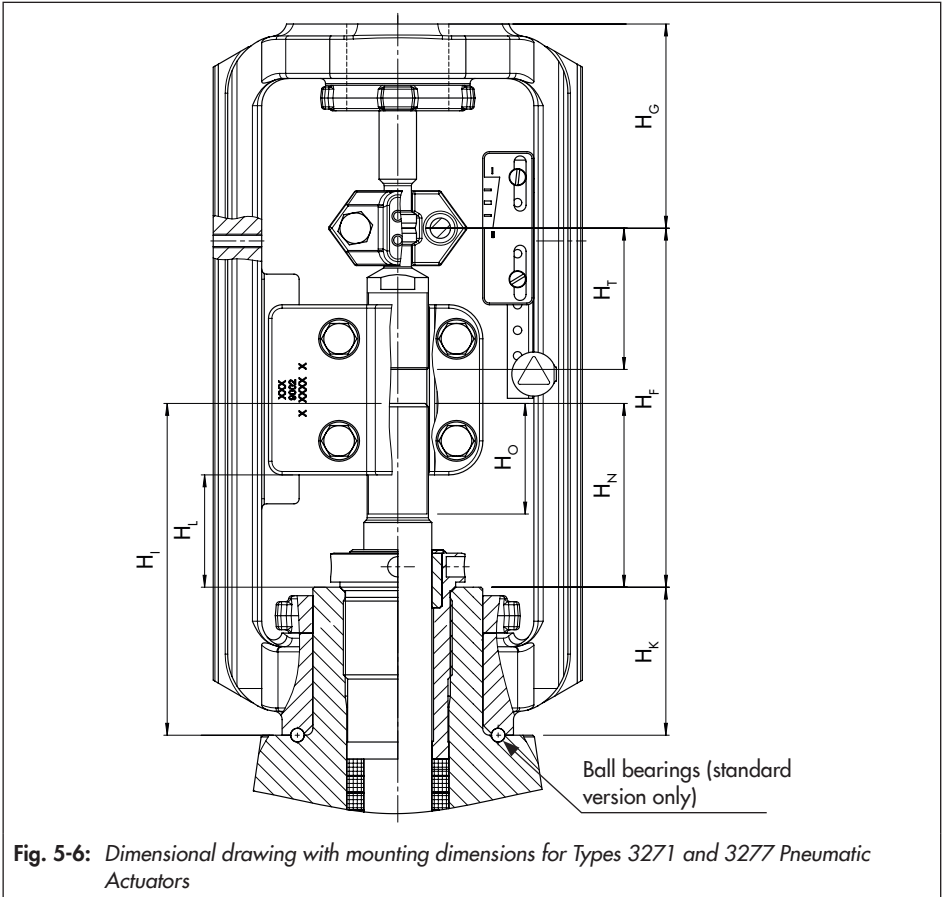

## 5.3.2 Mounting the actuator onto the valve

### **⚠ WARNING**

#### **Risk of personal injury due to preloaded springs.**

Actuators with preloaded springs are under tension. They can be identified by the long bolts protruding from the bottom of the actuator.

- Before starting any work on the actuator, relieve the compression from the preloaded springs (see associated actuator documentation).

### **⚠ WARNING**

#### **Risk of personal injury due to incorrect removal of the anti-rotation fixture under tension.**

Once the actuator has been mounted on the valve and the assembly is ready for use, the clamps (301) of the anti-rotation fixture on the plug stem are under tension.

- Follow the instructions in this document during mounting or removal.
- Do not loosen the screws (303) of the anti-rotation fixture while the force generated by the supply air and/or the actuator springs is transmitted to the actuator stem and the stem (9).
- First remove the actuator from the valve or ensure it cannot transmit any forces to the actuator stem before removing the anti-rotation fixture on the plug stem.

Depending on the version, SAMSON control valves are either delivered with the actuator already mounted on the valve or the valve and actuator are delivered separately. When delivered separately, the valve and actuator must be assembled together on site.

### **Versions with V-port plug**

To achieve the best flow conditions inside the valve, the V-port plug must always be installed with the port that releases the flow first when the valve opens facing toward the valve outlet. This is the largest of the three V-shaped ports (see Fig. 5-7).

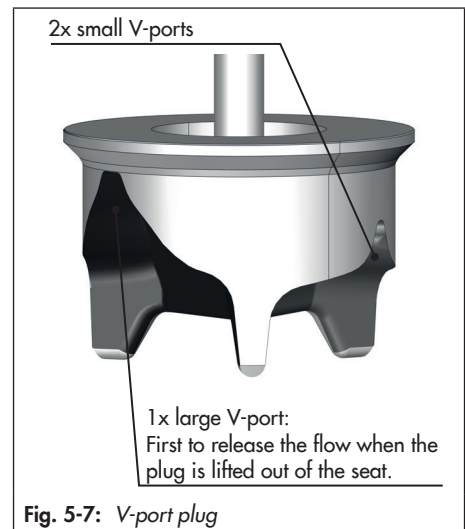

**Fig. 5-7:** V-port plug

- Before mounting the actuator, determine which V-shaped port is uncovered first when the plug is lifted out of the seat.
- On mounting the actuator, make sure that the V-shaped port uncovered first faces toward the valve outlet.

## Installation

### Versions with perforated plug

Only one hole is located near the seal facing of perforated plugs with equal percentage characteristic. Depending on the valve size, the hole pattern varies and is partly unsymmetrical. The process medium in the valve flows through the holes as soon as the plug is lifted out of the seat. To achieve the best flow conditions inside the valve, the perforated plug must always be installed with the hole that releases the flow first when the valve opens facing toward the valve outlet (see Fig. 5-8).

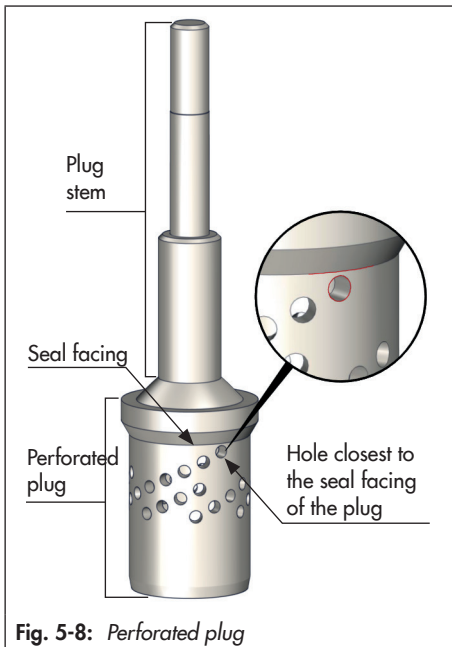

Fig. 5-8: Perforated plug

→ Before mounting the actuator, check the hole pattern of the perforated plug and determine which hole is the closest to the

seal facing and is uncovered first when the plug is lifted out of the seat.

→ On mounting the actuator, make sure that the hole uncovered first faces toward the valve outlet.

### a) Mounting the actuator

→ To mount the actuator, proceed as described in the associated actuator documentation.

### b) Aligning the travel indicator scale

After mounting the actuator, the travel indicator scale must be aligned. To do so, align '0' on the travel indicator scale with the tip of the stem connector clamp (see Fig. 5-6).

1. Move the valve to the closed position.
2. Loosen the screws on the travel indicator scale.
3. Align the travel indicator scale.
4. Fix the travel indicator scale into place by tightening the screws.

## 5.3.3 Installing the valve into the pipeline

### NOTICE

**Risk of valve damage due to work being carried out by personnel not qualified for such tasks.**

*The plant operator or specialist company performing the welding is responsible for the*

*selection of the welding procedure and the actual welding operations on the valve. This also applies to any required heat treatment to be performed on the valve.*

→ *Only allow qualified welding personnel to carry out welding operations.*

---

**! NOTICE**

**Premature wear and leakage due to insufficient support or suspension.**

→ *Support or suspend the valve sufficiently at suitable points.*

---

### a) Version with flanges

1. Close the shut-off valves in the pipeline at the inlet and outlet of the plant section while the valve is being installed.
2. Prepare the relevant section of the pipeline for installing the valve.
3. Remove the protective caps from the valve ports before installing the valve.
4. Lift the valve using suitable lifting equipment to the site of installation (see information under 'Lifting the valve' in the 'Shipment and on-site transport' section). Observe the flow direction through the valve. The arrow on the valve indicates the direction of flow.
5. Make sure that the correct flange gaskets are used.
6. Bolt the pipe to the valve free of stress.
7. Connect the cooling water pipeline and cooling water valve.

8. Attach a support or suspension on the valve, if necessary.

### b) Version with welding ends

1. Proceed as described for 'Version with flanges' (steps 1 to 4).
2. Completely retract the actuator stem to protect the plug from sparks during welding.
3. Weld the valve free of stress into the pipeline.
4. Connect the cooling water pipeline and cooling water valve.
5. Attach a support or suspension on the valve, if necessary.

## 5.4 Testing the installed valve

### **⚠ DANGER**

**Risk of bursting due to incorrect opening of pressurized equipment or components.**

Valves and pipelines are pressure equipment that may burst when handled incorrectly. Flying projectile fragments or the release of process medium under pressure can cause serious injury or even death.

Before working on the control valve:

- Depressurize all plant sections affected and the valve (including the actuator). Release any stored energy.
- Drain the process medium from all the plant sections concerned as well as the valve.

### **⚠ WARNING**

**Risk of personal injury due to pressurized components and process medium being discharged.**

- Do not loosen the screw of the test connection while the valve is pressurized.

### **⚠ WARNING**

**Risk of hearing loss or deafness due to loud noise.**

Noise emission (e.g. cavitation or flashing) may occur during operation caused by the process medium and the operating conditions. Additionally, a loud noise may briefly occur through the sudden venting of the pneumatic actuator or pneumatic valve accessories not fitted with noise-reducing fittings. Both can damage hearing.

- Wear hearing protection when working near the valve.

### **⚠ WARNING**

**Crush hazard arising from actuator and plug stem moving.**

- Do not insert hands or finger into the yoke while the air supply is connected to the actuator.
- Before working on the control valve, disconnect and lock the pneumatic air supply as well as the control signal.
- Do not impede the movement of the actuator and plug stem by inserting objects into the yoke.
- Before unblocking the actuator and plug stem after they have become blocked (e.g. due to seizing up after remaining in the same position for a long time), release any stored energy in the actuator (e.g. spring compression). See associated actuator documentation.

### **⚠ WARNING**

**Risk of personal injury due to exhaust air being vented.**

While the valve is operating, air is vented from the actuator, for example, during closed-loop operation or when the valve opens or closes.

- Wear eye protection when working in close proximity to the control valve.

**⚠ WARNING*****Risk of personal injury due to preloaded springs.***

*Actuators with preloaded springs are under tension. They can be identified by the long bolts protruding from the bottom of the actuator.*

➔ *Before starting any work on the actuator, relieve the compression from the preloaded springs (see associated actuator documentation).*

To test the valve functioning before start-up or putting back the valve into operation, perform the following tests:

**5.4.1 Leak test**

The plant operator is responsible for performing the leak test and selecting the test method. The leak test must comply with the requirements of the national and international standards that apply at the site of installation.

**Tip**

*Our after-sales service can support you to plan and perform a leak test for your plant.*

1. Close the valve.
2. Slowly apply the test medium to the inlet space upstream of the valve. A sudden surge in pressure and resulting high flow velocities can damage the valve.
3. Open the valve.

4. Apply the required test pressure.
5. Check the valve for leakage to the atmosphere.
6. Depressurize the pipeline section and valve.
7. Rework any parts that leak (see information below under 'Adjusting the packing') and repeat the leak test.

**Adjusting the packing**

A label on the yoke indicates whether an adjustable packing is installed (see the 'Markings on the device' section).

**⚠ NOTICE*****Impaired valve functioning due to increased friction as a result of the threaded bushing being tightened too far.***

➔ *Make sure that the plug stem can still move smoothly after the threaded bushing has been tightened.*

1. Tighten the threaded bushing gradually (by turning it clockwise) until the packing seals the valve.
  2. Open and close the valve several times.
  3. Check the valve for leakage to the atmosphere.
  4. Repeat steps 1 and 2 until the packing completely seals the valve.
- ➔ If the adjustable packing does not seal properly, contact our after-sales service.

### 5.4.2 Travel motion

The movement of the actuator stem must be linear and smooth.

- Apply the maximum and minimum control signals to check the end positions of the valve while observing the movement of the actuator stem.
- Check the travel reading at the travel indicator scale.

### 5.4.3 Fail-safe position

- Shut off the signal pressure line.
- Check whether the valve moves to the fail-safe position (see the 'Design and principle of operation' section).

### 5.4.4 Pressure test

The plant operator is responsible for performing the pressure test.



#### **Tip**

*Our after-sales service can support you to plan and perform a pressure test for your plant.*

---

During the pressure test, make sure the following conditions are met:

- Retract the plug stem to open the valve.
- Observe the maximum permissible pressure for both the valve and plant.



## 6 Start-up

The work described in this section is only to be performed by personnel appropriately qualified to carry out such tasks.

### **⚠ WARNING**

**Risk of burn injuries due to hot or cold components and pipeline.**

Valve components and the pipeline may become very hot or cold. Risk of burn injuries.

- Allow components and pipelines to cool down or warm up to the ambient temperature.
- Wear protective clothing and safety gloves.

### **⚠ WARNING**

**Risk of personal injury due to pressurized components and process medium being discharged.**

- Do not loosen the screw of the test connection while the valve is pressurized.

### **⚠ WARNING**

**Risk of hearing loss or deafness due to loud noise.**

Noise emission (e.g. cavitation or flashing) may occur during operation caused by the process medium and the operating conditions. Additionally, a brief loud noise may occur through the sudden venting of the pneumatic actuator (see 'Fail-safe position') or pneumatic valve accessories not fitted with noise-reducing fittings. Both can damage hearing.

- Wear hearing protection when working near the valve.

### **⚠ WARNING**

**Crush hazard arising from actuator and plug stem moving.**

- Do not insert hands or finger into the yoke while the air supply is connected to the actuator.
- Before working on the control valve, disconnect and lock the pneumatic air supply as well as the control signal.
- Do not impede the movement of the actuator and plug stem by inserting objects into the yoke.
- Before unblocking the actuator and plug stem after they have become blocked (e.g. due to seizing up after remaining in the same position for a long time), release any stored energy in the actuator (e.g. spring compression). See associated actuator documentation.

### **⚠ WARNING**

**Risk of personal injury due to exhaust air being vented.**

While the valve is operating, air is vented from the actuator, for example, during closed-loop operation or when the valve opens or closes.

- Wear eye protection when working in close proximity to the control valve.

## Start-up

Before start-up or putting the valve back into service, make sure the following conditions are met:

- The valve is properly installed into the pipeline (see the 'Installation' section).
- The leak and function tests have been completed successfully (see 'Testing the installed valve' in the 'Installation' section).
- The prevailing conditions in the plant section concerned meet the valve sizing requirements (see information under 'Intended use' in the 'Safety instructions and measures' section).

### Start-up/putting the valve back into operation

1. Allow the valve to cool down or warm up to reach ambient temperature before start-up when the ambient temperature and process medium temperature differ greatly or the medium properties require such a measure.
2. Set the controller (2) to 'manual' to ensure that the plant can slowly warm up by slightly opening the steam conditioning valve.
3. Set the controller (3) for the water supply to 'automatic' to ensure it can react quickly to changes at the temperature sensor of the transmitter.
4. Slowly open the shut-off valves in the pipeline. Slowly opening these valves prevents a sudden surge in pressure and high flow velocities which can damage the valve.

5. Check the valve to ensure it functions properly.

## 7 Operation

Immediately after completing start-up or putting the valve back into operation, the valve is ready for use.

### **⚠ WARNING**

**Risk of burn injuries due to hot or cold components and pipeline.**

Valve components and the pipeline may become very hot or cold. Risk of burn injuries.

- Allow components and pipelines to cool down or warm up to the ambient temperature.
- Wear protective clothing and safety gloves.

### **⚠ WARNING**

**Risk of personal injury due to pressurized components and process medium being discharged.**

- Do not loosen the screw of the test connection while the valve is pressurized.

### **⚠ WARNING**

**Risk of hearing loss or deafness due to loud noise.**

Noise emission (e.g. cavitation or flashing) may occur during operation caused by the process medium and the operating conditions. Additionally, a loud noise may briefly occur through the sudden venting of the pneumatic actuator or pneumatic valve accessories not fitted with noise-reducing fittings. Both can damage hearing.

- Wear hearing protection when working near the valve.

### **⚠ WARNING**

**Crush hazard arising from actuator and plug stem moving.**

- Do not insert hands or finger into the yoke while the air supply is connected to the actuator.
- Before working on the control valve, disconnect and lock the pneumatic air supply as well as the control signal.
- Do not impede the movement of the actuator and plug stem by inserting objects into the yoke.
- Before unblocking the actuator and plug stem after they have become blocked (e.g. due to seizing up after remaining in the same position for a long time), release any stored energy in the actuator (e.g. spring compression). See associated actuator documentation.

### **⚠ WARNING**

**Risk of personal injury due to exhaust air being vented.**

While the valve is operating, air is vented from the actuator, for example, during closed-loop operation or when the valve opens or closes.

- Wear eye protection when working in close proximity to the control valve.

## Operation

### 7.1 Normal operation

The handwheel of valves with actuators fitted with a handwheel must be in the neutral position during normal operation.

### 7.2 Manual operation

Valves with actuators fitted with a handwheel can be manually closed or opened in case of supply air failure.

## 8 Malfunctions

Read hazard statements, warnings and caution notes in the 'Safety instructions and measures' section.

### 8.1 Troubleshooting

Malfunction	Possible reasons	Recommended action
Actuator and plug stem does not move on demand.	Actuator is blocked.	Check attachment. Remove the blockage. <b>WARNING!</b> A blocked actuator or plug stem (e.g. due to seizing up after remaining in the same position for a long time) can suddenly start to move uncontrollably. Injury to hands or fingers is possible if they are inserted into the actuator or valve. Before trying to unblock the actuator or plug stem, disconnect and lock the pneumatic air supply as well as the control signal. Before unblocking the actuator, release any stored energy in the actuator (e.g. spring compression). See associated actuator documentation.
	Diaphragm in the actuator defective	See associated actuator documentation.
	Signal pressure too low	Check the signal pressure. Check the signal pressure line for leakage.
Jolting movement of the actuator and plug stem	Version with adjustable packing <sup>1)</sup> ; packing not tightened correctly	Tighten the packing correctly (see information under 'Adjusting the packing' in the 'Installation' section > 'Testing the installed valve').
Actuator and plug stem does not stroke through the entire range.	Signal pressure too low	Check the signal pressure. Check the signal pressure line for leakage.
	Travel stop active	See associated actuator documentation.
	Incorrect setting of valve accessories	Check the settings of the valve accessories.

## Malfunctions

Malfunction	Possible reasons	Recommended action
Increased flow through closed valve (seat leakage)	Dirt or other foreign particles deposited between the seat and plug.	Shut off the section of the pipeline and flush the valve.
	Valve trim is worn out.	Replace seat and plug (see the 'Servicing' section) or contact our after-sales service.
	Sealing parts, weld spatter and other impurities carried along by the steam have accumulated.	Pickle and blow through the steam pipe.
The valve leaks to the atmosphere (fugitive emissions).	Defective packing	Replace packing (see the 'Servicing' section) or contact our after-sales service.
	Version with adjustable packing <sup>1)</sup> : packing not tightened correctly	Adjust the packing (see information under 'Adjusting the packing' in the 'Installation' section > 'Testing the installed valve'). Contact our after-sales service when it continues to leak.
	Version with bellows seal: the bellows seal is defective.	Contact our after-sales service.
	Flange joint loose or gasket worn out	Check the flange joint. Replace gasket at the flanged joint (see the 'Servicing' section) or contact our after-sales service.

<sup>1)</sup> See the 'Markings on the device' section

### **i** Note

Contact our after-sales service for malfunctions not listed in the table.

## 8.2 Emergency action

Plant operators are responsible for emergency action to be taken in the plant.

In the event of a valve malfunction:

1. Close the shut-off valves upstream and downstream of the control valve to stop the process medium from flowing through the valve.
2. Perform troubleshooting (see section 8.1).
3. Rectify those malfunctions that can be remedied based on the instructions provided here. Contact our after-sales service in all other cases.

### **Putting the valve back into operation after a malfunction**

See the 'Start-up' section.





## 9 Servicing

The work described in this section is only to be performed by personnel appropriately qualified to carry out such tasks.

The following documents are also required for servicing the valve:

- Mounting and operating instructions for the mounted actuator, e.g. ► EB 8310-X for Type 3271 or Type 3277 Pneumatic Actuator
- ► AB 0100 for tools, tightening torques and lubricant

### **⚠ DANGER**

**Risk of bursting due to incorrect opening of pressurized equipment or components.**

Valves and pipelines are pressure equipment that may burst when handled incorrectly. Flying projectile fragments or the release of process medium under pressure can cause serious injury or even death.

Before working on the control valve:

- ➔ Depressurize all plant sections affected and the valve (including the actuator). Release any stored energy.
- ➔ Drain the process medium from all the plant sections concerned as well as the valve.

### **⚠ WARNING**

**Risk of personal injury due to pressurized components and process medium being discharged.**

- ➔ Do not loosen the screw of the test connection while the valve is pressurized.

### **⚠ WARNING**

**Risk of burn injuries due to hot or cold components and pipeline.**

Valve components and the pipeline may become very hot or cold. Risk of burn injuries.

- ➔ Allow components and pipelines to cool down or warm up to the ambient temperature.
- ➔ Wear protective clothing and safety gloves.

### **⚠ WARNING**

**Risk of hearing loss or deafness due to loud noise.**

Noise emission (e.g. cavitation or flashing) may occur during operation caused by the process medium and the operating conditions. Additionally, a loud noise may briefly occur through the sudden venting of the pneumatic actuator or pneumatic valve accessories not fitted with noise-reducing fittings. Both can damage hearing.

- ➔ Wear hearing protection when working near the valve.

### **⚠ WARNING**

**Crush hazard arising from actuator and plug stem moving.**

- ➔ Do not insert hands or finger into the yoke while the air supply is connected to the actuator.
- ➔ Before working on the control valve, disconnect and lock the pneumatic air supply as well as the control signal.

## Servicing

- Do not impede the movement of the actuator and plug stem by inserting objects into the yoke.
- Before unblocking the actuator and plug stem after they have become blocked (e.g. due to seizing up after remaining in the same position for a long time), release any stored energy in the actuator (e.g. spring compression). See associated actuator documentation.

### WARNING

#### **Risk of personal injury due to exhaust air being vented.**

While the valve is operating, air is vented from the actuator, for example, during closed-loop operation or when the valve opens or closes.

- Wear eye protection when working in close proximity to the control valve.

### WARNING

#### **Risk of personal injury due to preloaded springs.**

Actuators with preloaded springs are under tension. They can be identified by the long bolts protruding from the bottom of the actuator.

- Before starting any work on the actuator, relieve the compression from the preloaded springs (see associated actuator documentation).

### WARNING

#### **Risk of personal injury due to residual process medium in the valve.**

While working on the valve, residual medium can flow out of the valve and, depending on its properties, cause personal injury, e.g. (chemical) burns.

- Wear protective clothing, safety gloves, respiratory protection and eye protection.

### NOTICE

#### **Risk of valve damage due to excessively high or low tightening torques.**

Observe the specified torques when tightening control valve components. Excessive tightening torques lead to parts wearing out more quickly. Parts that are too loose may cause leakage.

- Observe the specified tightening torques (▶ AB 0100).

### NOTICE

#### **Risk of valve damage due to the use of unsuitable tools.**

- Only use tools approved by SAMSON (▶ AB 0100).

### NOTICE

#### **Risk of valve damage due to the use of unsuitable lubricants.**

- Only use lubricants approved by SAMSON (▶ AB 0100).

**i Note**

The control valve was checked by SAMSON before it left the factory.

- Certain test results certified by SAMSON lose their validity when the valve is opened. Such testing includes seat leakage and leak tests.
- The product warranty becomes void if service or repair work not described in these instructions is performed without prior agreement by SAMSON's After-sales Service.
- Only use original spare parts by SAMSON, which comply with the original specifications.

## 9.1 Periodic testing

Depending on the operating conditions, check the valve at certain intervals to prevent possible failure before it can occur. Plant operators are responsible for drawing up an inspection and test plan.

 **Tip**

Our after-sales service can support you in drawing up an inspection and test plan for your plant.

We recommend the following inspection and testing which can be performed while the process is running:

Inspection and testing	Action to be taken in the event of a negative result:
Check the markings, labels and nameplates on the valve for their readability and completeness.	Immediately renew damaged, missing or incorrect nameplates or labels.
	Clean any inscriptions that are covered with dirt and are illegible.
Check the pipe connections and gaskets on the valve and actuator for leakage.	Check the bolted joint (tightening torque).
	Replace the gasket on the flanged joint as described in section 9.4.1.
	Version with adjustable packing <sup>1)</sup> : adjust the packing (see information under 'Adjusting the packing' in the 'Testing the installed valve' section) or replace the packing (see section 9.4.2).

## Servicing

Inspection and testing	Action to be taken in the event of a negative result:
Check the test connection and bellows seal (if used) for external leakage. <b>WARNING!</b> Risk of personal injury due to pressurized components and process medium being discharged. Do not loosen the screw of the test connection while the valve is pressurized.	Put the control valve out of operation (see the 'Decommissioning' section). To repair the bellows seal, contact our after-sales service (see the 'Repairs' section).
Check the valve's seat leakage.	Shut off the section of the pipeline and flush the valve to remove any dirt and/or deposited foreign particles between the seat and plug.
Check the valve for external damage (e.g. corrosion).	Repair any damage immediately. If necessary, put the control valve out of operation (see the 'Decommissioning' section).
Check the valve accessories to ensure they are mounted properly.	Tighten the connections of the valve accessories.
Check to ensure that the actuator and plug stem move smoothly.	Version with adjustable packing <sup>1)</sup> : tighten the packing correctly (see information under 'Adjusting the packing' in the 'Testing the installed valve' section).
	Unblock a blocked actuator and plug stem. <b>WARNING!</b> A blocked actuator or plug stem (e.g. due to seizing up after remaining in the same position for a long time) can suddenly start to move uncontrollably. Injury to hands or fingers is possible if they are inserted into the actuator or valve. Before trying to unblock the actuator or plug stem, disconnect and lock the pneumatic air supply as well as the control signal. Before unblocking the actuator, release any stored energy in the actuator (e.g. spring compression). See associated actuator documentation.
If possible, check the valve's fail-safe position by briefly interrupting the air supply.	Put the control valve out of operation (see the 'Decommissioning' section). Identify the cause for the malfunction and rectify it (see the 'Troubleshooting' section).

<sup>1)</sup> See the 'Markings on the device' section

## 9.2 Preparing the valve for service work

### **⚠ WARNING**

**Risk of personal injury due to incorrect removal of the anti-rotation fixture under tension.**

Once the actuator has been mounted on the valve and the assembly is ready for use, the clamps (301) of the anti-rotation fixture on the plug stem are under tension.

- Follow the instructions in this document during mounting or removal.
- Do not loosen the screws (303) of the anti-rotation fixture while the force generated by the supply air and/or the actuator springs is transmitted to the actuator stem and the stem (9).
- First remove the actuator from the valve or ensure it cannot transmit any forces to the actuator stem before removing the anti-rotation fixture on the plug stem.

1. Lay out the necessary material and tools to have them ready for the service work.
2. Put the control valve out of operation (see the 'Decommissioning' section).
3. Undo the flange joint between the cooling water valve and steam conditioning valve.
4. Remove the steam conditioning valve from the pipeline (see the 'Removal' section).
5. Remove the actuator from the valve. See associated actuator documentation.

### **i Note**

To remove an actuator with "stem extends" fail-safe action and/or with preloaded springs, a certain signal pressure must be applied to the actuator (see associated actuator documentation). Afterwards, the signal pressure must be removed and the air supply disconnected again and locked.

The following service work can be performed after preparation is completed:

- Replace the gaskets as described in section 9.4.1.
- Replace the packing (see section 9.4.2)
- Replace the seat and plug (see section 9.4.3)
- Determine the number of shims required (see section 9.4.4).

## 9.3 Installing the valve after service work

1. Mount actuator. See associated actuator documentation and the 'Installation' section.
2. Adjust lower or upper signal bench range. See associated actuator documentation.
3. Install the valve into the pipeline (see the 'Installation' section).
4. Put the control valve back into operation (see the 'Start-up' section). Observe the requirements and conditions for start-up or putting the valve back into operation.

### 9.4 Service work

- Before performing any service work, preparations must be made to the control valve (see section 9.2).
- After all service work is completed, check the control valve before putting it back into operation (see 'Testing the installed valve' in the 'Installation' section).

#### 9.4.1 Replacing gaskets

##### **NOTICE**

##### **Risk of control valve damage due to incorrect servicing.**

- *The gaskets can only be replaced when all the following conditions are met:*
  - *The valve size is  $\leq$ NPS 6.*
  - *The valve does not have a balanced plug.*
  - *The valve does not have a bellows seal.*
  - *The valve does not have an insulating section.*
- *To replace the gaskets in other valve versions, contact our after-sales service.*

The following gaskets are installed and must be exchanged:

- Body gasket (17)
- Shims 0.5 mm (64)
- Shims 2 mm (65)
- Graphite fiber packing (67)

##### **i Note**

*Measure how many shims (64, 65) are required (see section 9.4.4).*

1. Undo the body nuts (14) gradually in a crisscross pattern.
2. Lift the bonnet (2), yoke (3) and plug with plug stem (5) off the body (1).
3. Remove the gaskets (17, 64, 65) and graphite fiber packing (67). Carefully clean the sealing faces in the valve body (1), on the bonnet (2) and clamping element (63).
4. Insert a new gasket (17) into the body.
5. Place the new graphite fiber packing (67) on the clamping element (63).
6. Place the new shims (64, 65) on the graphite fiber packing. For this purpose, measure how many shims are required as described in section 9.4.4.
7. Make sure that the flow divider (62) is still clamped correctly on the seat (4).
8. Place the bonnet (2) together with the plug stem and plug (5) onto the body.  
**Version with V-port plug:** place the bonnet (2) onto the valve body, making sure that the largest V-shaped port of the V-port plug faces towards the valve outlet.  
**Version with perforated plug:** place the bonnet (2) onto the valve body, making sure that the hole of the plug that releases the flow first faces toward the valve outlet.  
See relevant information under 'Mounting the actuator onto the valve' in the 'Installation' section.
9. Firmly press the plug (5) into the seat (4). Fasten down the bonnet (2) with the

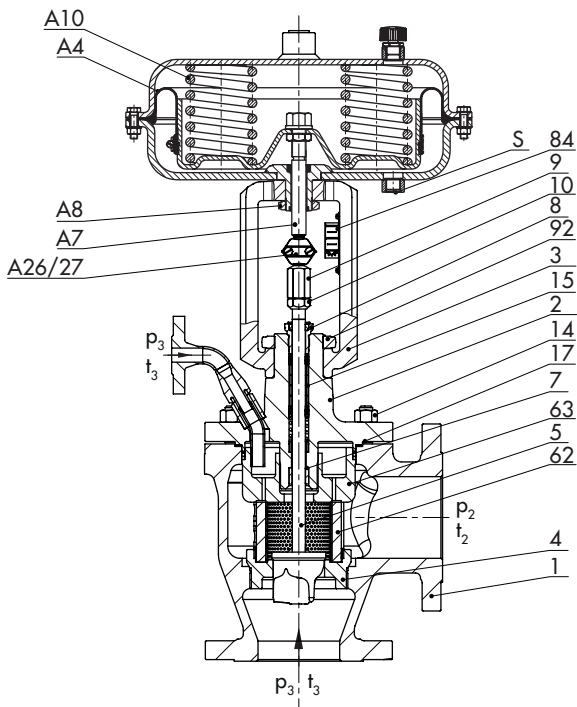

- |    |                                |        |                            |
|----|--------------------------------|--------|----------------------------|
| 1  | Body                           | 17     | Body gasket                |
| 2  | Bonnet (with connecting pipe)  | 62     | Flow divider ST 3          |
| 3  | Yoke                           | 63     | Clamping element           |
| 4  | Seat                           | 84     | Travel indicator scale     |
| 5  | Plug (with plug stem)          | 92     | Castellated nut            |
| 7  | Guide bushing                  | A4     | Diaphragm                  |
| 8  | Threaded bushing (packing nut) | A7     | Actuator stem              |
| 9  | Stem connector nut             | A8     | Ring nut                   |
| 10 | Lock nut                       | A10    | Spring                     |
| 14 | Body nut                       | A26/27 | Stem connector clamps      |
| 15 | Packing                        | S      | Signal pressure connection |

Fig. 9-1: Type 3286 with Type 3271 Actuator

## Servicing

body nuts (14). Tighten the nuts gradually in a crisscross pattern. Observe tightening torques.

### 9.4.2 Replacing the packing

#### ⓘ NOTICE

**Risk of control valve damage due to incorrect servicing.**

- The packing can only be replaced when all the following conditions are met:
- The valve size is  $\leq$ NPS 6.
  - The valve does not have a balanced plug.
  - The valve does not have a bellows seal.
  - The valve does not have an insulating section.
  - The standard packing, form H or form HT packing is installed in the valve.
- To replace the packing in other valve versions, contact our after-sales service.

#### ⓘ NOTICE

**Damage to the packing (form H or form HT) through the use of lubricant.**

The form H and form HT packings contain graphite.

- Do not use any lubricant during the installation of this packing.

#### i Note

The number of spacers (19) varies depending on the nominal valve size.

### a) Standard and form H packings

1. Unscrew the castellated nut (92) and lift the yoke (3) off the bonnet (2).
2. Undo the body nuts (14) gradually in a crisscross pattern.
3. Lift the bonnet (2) and plug with plug stem (5) off the body (1).
4. Replace the gaskets as described in section 9.4.1.
5. Unscrew the stem connector nut (9) and lock nut (10) from the plug stem.
6. Unscrew the threaded bushing (8).
7. Pull the plug with plug stem (5) out of the bonnet (2).
8. Pull the entire packing out of the packing chamber using a suitable tool.
9. Renew damaged parts. Clean the packing chamber thoroughly.
10. **Standard packing:** apply a suitable lubricant to all the packing parts and to the plug stem (5).

**Form H packing:** do not use any lubricant.

11. Slide the plug with plug stem (5) into the bonnet (2).
  12. Make sure that the flow divider (62) is still clamped correctly on the seat (4).
  13. Place the bonnet (2) together with the plug stem and plug (5) onto the body.
- Version with V-port plug:** place the bonnet (2) onto the valve body, making sure that the largest V-shaped part of the



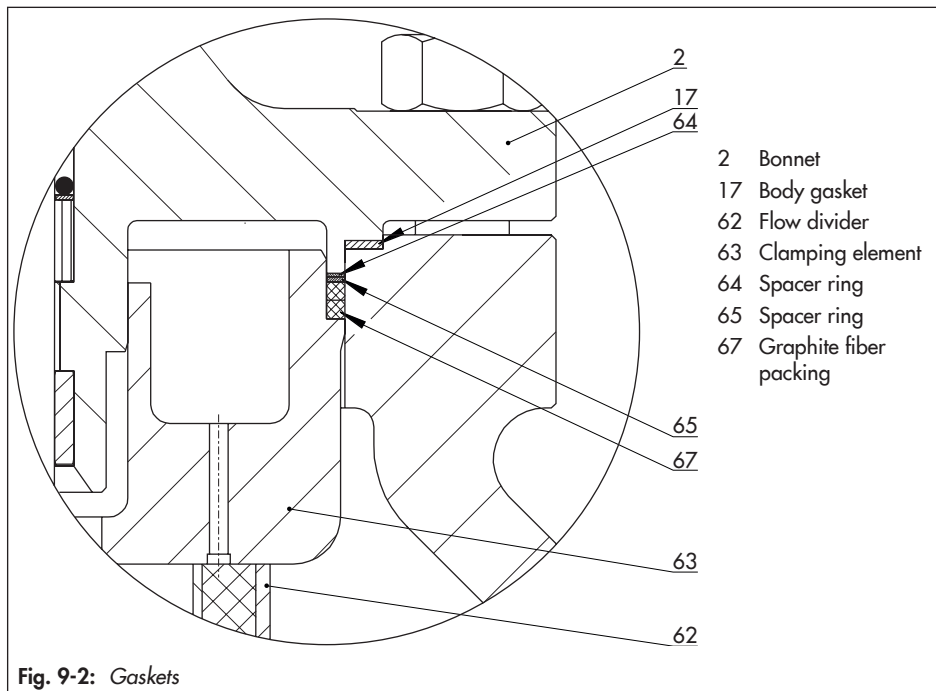

V-port plug faces towards the valve outlet.

**Version with perforated plug:** place the bonnet (2) onto the valve body, making sure that the hole of the plug that releases the flow first faces toward the valve outlet.

See relevant information under 'Mounting the actuator onto the valve' in the 'Installation' section.

14. Carefully slide the packing parts over the plug stem into the packing chamber using a suitable tool. Observe the proper sequence (see Fig. 9-3).

15. Firmly press the plug (5) into the seat (4). Fasten down the bonnet (2) with the body nuts (14). Tighten the nuts gradually in a crisscross pattern. Observe tightening torques.
16. Screw in the threaded bushing (8) and tighten it. Observe tightening torques.
17. Place yoke (3) on the bonnet (2) and fasten using the castellated nut (92).
18. Loosely screw the lock nut (10) and stem connector nut (9) onto the plug stem.

## b) Form HT packing

1. Proceed as described in 'Standard and form H packings', steps 1 to 15. Do not use any lubricant.
2. To compress the packing, tighten the packing until reaching the metal stop using a suitable tool.
3. Remove the tool.
4. Proceed as described in 'Standard and form H packings', steps 16 to 18.

→ After mounting the actuator, stroke the plug stem (5) up and down around ten times to allow the packing to settle.

### 9.4.3 Replacing the seat and plug

**NOTICE**

**Risk of control valve damage due to incorrect servicing.**

→ *Seat and plug can only be replaced when all the following conditions are met:*

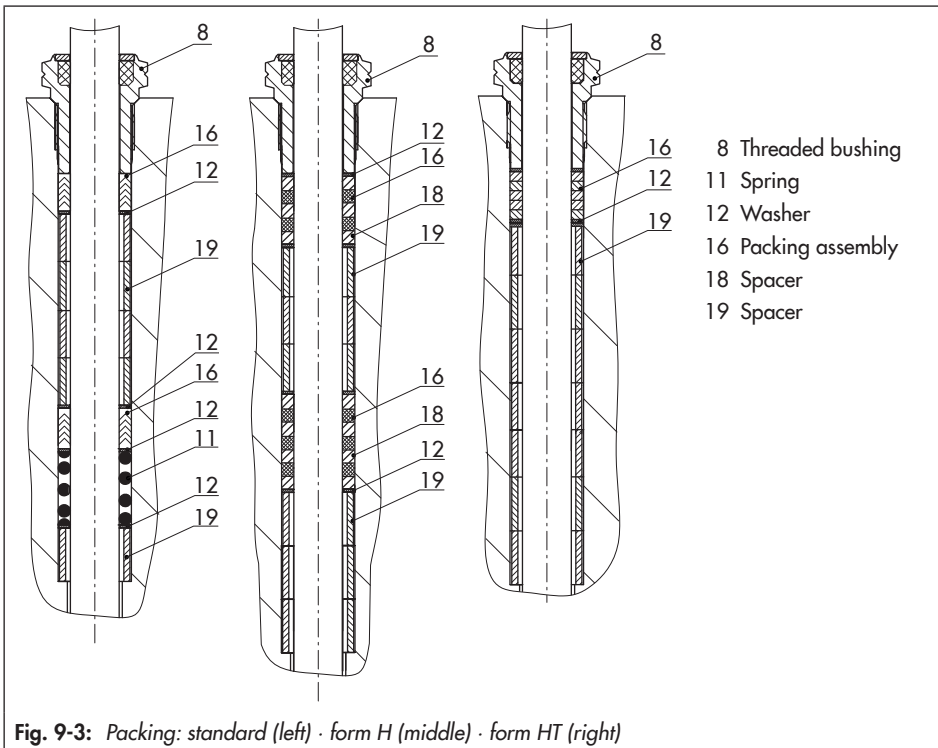

- The valve size is  $\leq$ NPS 6.
  - The valve does not have a balanced plug.
  - The valve does not have a bellows seal.
  - The valve does not have an insulating section.
  - The standard packing, form H or form HT packing is installed in the valve.
- To replace seat and plug in other valve versions, contact our after-sales service.

**NOTICE**

**Risk of damage to the facing of the seat and plug due to incorrect servicing.**

→ Always replace both the seat and plug.

1. Unscrew the castellated nut (92) and lift the yoke (3) off the bonnet (2).
2. Undo the body nuts (14) gradually in a crisscross pattern.
3. Lift the bonnet (2) and plug with plug stem (5) off the body (1).
4. Replace the gaskets as described in section 9.4.1.
5. Unscrew the stem connector nut (9) and lock nut (10) from the plug stem.
6. Unscrew the threaded bushing (8).
7. Pull the plug with plug stem (5) out of the bonnet (2).
8. Replace the packing (see section 9.4.2)
9. Make sure that the guide bushing (7) is not damaged. If necessary, replace the guide bushing using a suitable tool.
10. Remove clamping element (63) and flow divider (62).
11. Unscrew the seat (4) using a suitable tool.
12. Apply a suitable lubricant to the thread and the sealing cone of the new seat.
13. Screw in the seat (4). Observe tightening torques.
14. Clamp the flow divider (62) on the seat. Mount the clamping element (63).
15. Slide the new plug with plug stem (5) into the bonnet (2).
16. Place the bonnet (2) together with the plug stem and plug (5) onto the body (1).  
**Version with V-port plug:** place the bonnet (2) onto the valve body, making sure that the largest V-shaped part of the V-port plug faces towards the valve outlet.  
**Version with perforated plug:** place the bonnet (2) onto the valve body, making sure that the hole of the plug that releases the flow first faces toward the valve outlet.  
 See relevant information under 'Mounting the actuator onto the valve' in the 'Installation' section.
17. Firmly press the plug (5) into the seat (4). Fasten down the bonnet (2) with the body nuts (14). Tighten the nuts gradually in a crisscross pattern. Observe tightening torques.
18. Screw in the threaded bushing (8) and tighten it. Observe tightening torques.

## Servicing

19. Place yoke (3) on the bonnet (2) and fasten using the castellated nut (92).
20. Loosely screw the lock nut (10) and stem connector nut (9) onto the plug stem.
6. If dimension X  $\geq$  dimension S, insert an additional graphite fiber packing (67).

### 9.4.4 Determining the number of shims required

Determine the number of shims required every time the bonnet (2) is opened. Two different shim sizes are available:

- Shims 0.5 mm (64)
- Shims 2 mm (65)

After inserting the new gasket (17) as described in section 9.4.1, proceed as follows:

1. Determine dimension A.
2. Determine dimension B.
3. Refer to Table 9-1 for dimensions P and S.
4. Calculate dimension X:  
$$X = (A + P - B) - 2 * S$$
5. Fill out dimension x with the sufficient number of shims (64/65) up to +0.5 mm.

**Table 9-1:** Dimensions for graphite fiber packing

Dimension		Up to NPS 4	NPS 6 to 10	NPS 12
S	mm	4	8	10
P	mm	1.8	3	3.5

#### **i** Note

The dimension P is the height of the double-layered graphite fiber packing (67) in the compressed state.

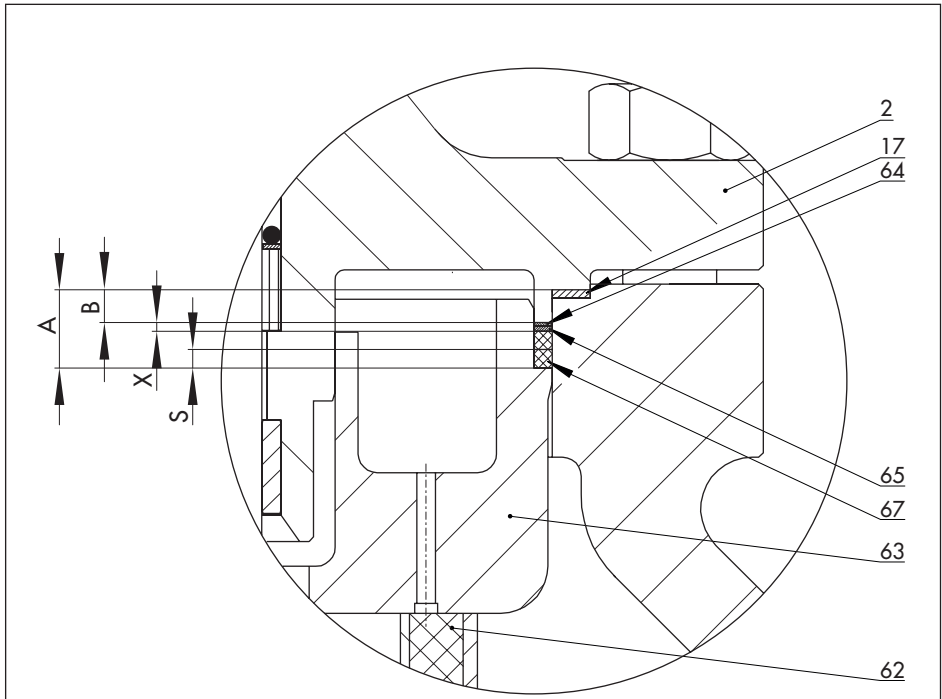

Dimension	Explanation
A	Bottom of the graphite fiber packing (67) up to the top of the gasket (17)
B	Top of the shim (64/65) up to the top of the gasket (17)
S	Height of the double-layered graphite fiber packing (67) (before compression)
X	Height of the shims (64/65)

- 2 Bonnet
- 17 Body gasket
- 62 Flow divider
- 63 Clamping element
- 64 Spacer ring
- 65 Spacer ring
- 67 Graphite fiber packing

Fig. 9-4: Shims at the flow divider

### 9.5 Ordering spare parts and operating supplies

Contact your nearest SAMSON subsidiary or SAMSON's After-sales Service for information on spare parts, lubricants and tools.

#### Spare parts

See Annex for details on spare parts.

#### Lubricant

See document ► AB 0100 for details on suitable lubricants.

#### Tools

See document ► AB 0100 for details on suitable tools.

## 10 Decommissioning

The work described in this section is only to be performed by personnel appropriately qualified to carry out such tasks.

### **⚠ DANGER**

**Risk of bursting due to incorrect opening of pressurized equipment or components.**

Valves and pipelines are pressure equipment that may burst when handled incorrectly.

Flying projectile fragments or the release of process medium under pressure can cause serious injury or even death.

Before working on the control valve:

- Depressurize all plant sections affected and the valve (including the actuator). Release any stored energy.
- Drain the process medium from all the plant sections concerned as well as the valve.

### **⚠ WARNING**

**Risk of burn injuries due to hot or cold components and pipeline.**

Valve components and the pipeline may become very hot or cold. Risk of burn injuries.

- Allow components and pipelines to cool down or warm up to the ambient temperature.
- Wear protective clothing and safety gloves.

### **⚠ WARNING**

**Risk of personal injury due to pressurized components and process medium being discharged.**

- Do not loosen the screw of the test connection while the valve is pressurized.

### **⚠ WARNING**

**Risk of hearing loss or deafness due to loud noise.**

Noise emission (e.g. cavitation or flashing) may occur during operation caused by the process medium and the operating conditions. Additionally, a loud noise may briefly occur through the sudden venting of the pneumatic actuator or pneumatic valve accessories not fitted with noise-reducing fittings. Both can damage hearing.

- Wear hearing protection when working near the valve.

### **⚠ WARNING**

**Crush hazard arising from actuator and plug stem moving.**

- Do not insert hands or finger into the yoke while the air supply is connected to the actuator.
- Before working on the control valve, disconnect and lock the pneumatic air supply as well as the control signal.
- Do not impede the movement of the actuator and plug stem by inserting objects into the yoke.
- Before unblocking the actuator and plug stem after they have become blocked

## Decommissioning

(e.g. due to seizing up after remaining in the same position for a long time), release any stored energy in the actuator (e.g. spring compression). See associated actuator documentation.

---

### **WARNING**

#### **Risk of personal injury due to exhaust air being vented.**

While the valve is operating, air is vented from the actuator, for example, during closed-loop operation or when the valve opens or closes.

→ Wear eye protection when working in close proximity to the control valve.

---

### **WARNING**

#### **Risk of personal injury due to residual process medium in the valve.**

While working on the valve, residual medium can flow out of the valve and, depending on its properties, cause personal injury, e.g. (chemical) burns.

→ Wear protective clothing, safety gloves, respiratory protection and eye protection.

---

To decommission the control valve for service work or to remove it from the pipeline, proceed as follows:

1. Close the shut-off valves upstream and downstream of the control valve to stop the process medium from flowing through the valve.

2. Completely drain the pipelines and valve.
3. Disconnect and lock the pneumatic air supply to depressurize the actuator.
4. Release any stored energy.
5. If necessary, allow the pipeline and valve components to cool down or warm up to the ambient temperature.
6. Remove the cooling water pipeline.



## 11 Removal

The work described in this section is only to be performed by personnel appropriately qualified to carry out such tasks.

### **⚠ WARNING**

#### **Risk of burn injuries due to hot or cold components and pipeline.**

Valve components and the pipeline may become very hot or cold. Risk of burn injuries.

- Allow components and pipelines to cool down or warm up to the ambient temperature.
- Wear protective clothing and safety gloves.

### **⚠ WARNING**

#### **Crush hazard arising from actuator and plug stem moving.**

- Do not insert hands or finger into the yoke while the air supply is connected to the actuator.
- Before working on the control valve, disconnect and lock the pneumatic air supply as well as the control signal.
- Do not impede the movement of the actuator and plug stem by inserting objects into the yoke.
- Before unblocking the actuator and plug stem after they have become blocked (e.g. due to seizing up after remaining in the same position for a long time), release any stored energy in the actuator (e.g. spring compression). See associated actuator documentation.

### **⚠ WARNING**

#### **Risk of personal injury due to residual process medium in the valve.**

While working on the valve, residual medium can flow out of the valve and, depending on its properties, cause personal injury, e.g. (chemical) burns.

- Wear protective clothing, safety gloves, respiratory protection and eye protection.

### **⚠ WARNING**

#### **Risk of personal injury due to preloaded springs.**

Actuators with preloaded springs are under tension. They can be identified by the long bolts protruding from the bottom of the actuator.

- Before starting any work on the actuator, relieve the compression from the preloaded springs.

### **⚠ WARNING**

#### **Risk of personal injury due to incorrect removal of the anti-rotation fixture under tension.**

Once the actuator has been mounted on the valve and the assembly is ready for use, the clamps (301) of the anti-rotation fixture on the plug stem are under tension.

- Follow the instructions in this document during mounting or removal.
- Do not loosen the screws (303) of the anti-rotation fixture while the force generated by the supply air and/or the actuator

## Removal

*springs is transmitted to the actuator stem and the stem (9).*

- *First remove the actuator from the valve or ensure it cannot transmit any forces to the actuator stem before removing the anti-rotation fixture on the plug stem.*
- 

Before removing the valve, make sure the following conditions are met:

- The control valve is put out of operation (see the 'Decommissioning' section).

### 11.1 Removing the valve from the pipeline

#### a) Version with flanges

1. Support the valve to hold it in place when separated from the pipeline (see the 'Shipment and on-site transport' section).
2. Unbolt the flange joint.
3. Remove the valve from the pipeline (see the 'Shipment and on-site transport' section).

#### b) Version with welding ends

1. Support the valve to hold it in place when separated from the pipeline (see the 'Shipment and on-site transport' section).
2. Cut the pipeline in front of the weld seam.

3. Remove the valve from the pipeline (see the 'Shipment and on-site transport' section).

### 11.2 Removing the actuator from the valve

See associated actuator documentation.

## 12 Repairs

If the valve does not function properly according to how it was originally sized or does not function at all, it is defective and must be repaired or exchanged.

### ! NOTICE

**Risk of valve damage due to incorrect service or repair work.**

- ➔ Do not perform any repair work on your own.
- ➔ Contact SAMSON's After-sales Service for service and repair work.

### 12.1 Returning devices to SAMSON

Defective devices can be returned to SAMSON for repair.

Proceed as follows to return devices:

1. Exceptions apply concerning some special device models
  - ▶ [www.samsongroup.com](http://www.samsongroup.com) > Service > After-sales Service > Returning goods.
2. Send an e-mail
  - ▶ [returns-de@samsongroup.com](mailto:returns-de@samsongroup.com) to register the return shipment including the following information:
    - Type
    - Article number
    - Configuration ID
    - Original order

- Completed Declaration on Contamination, which can be downloaded from our website at
  - ▶ [www.samsongroup.com](http://www.samsongroup.com) > Service > After-sales Service > Returning goods.

**After checking your registration, we will send you a return merchandise authorization (RMA).**

3. Attach the RMA (together with the Declaration on Decontamination) to the outside of your shipment so that the documents are clearly visible.
4. Send the shipment to the address given on the RMA.

### i Note

*Further information on returned devices and how they are handled can be found at*

- ▶ [www.samsongroup.com](http://www.samsongroup.com) > Service > After-sales Service.



## 13 Disposal



SAMSON is a producer registered at the following European institution  
 ► <https://www.ewrn.org/national-registers/national-registers>.  
 WEEE reg. no.: DE 62194439/  
 FR 02566

- ➔ Observe local, national and international refuse regulations.
- ➔ Do not dispose of components, lubricants and hazardous substances together with your household waste.

---

### **i** Note

*We can provide you with a recycling passport according to PAS 1049<sup>1)</sup> on request. Simply e-mail us at [offersaleservice@samsongroup.com](mailto:offersaleservice@samsongroup.com) giving details of your company address.*

---

### Tip

*On request, we can appoint a service provider to dismantle and recycle the product as part of a distributor take-back scheme.*

---

<sup>1)</sup> PAS 1049 is relevant to electrical and electronic equipment (e.g. electric actuators). This PAS specification does not apply to non-electrical equipment.



## 14 Certificates

The declaration is provided on the next page:

- Declaration of conformity in compliance with Machinery Directive 2006/42/EC for Types 3286-1 and 3286-7 Control Valves

The certificate shown was up to date at the time of publishing. The latest certificates can be found on our website:

▶ [www.samsongroup.com](http://www.samsongroup.com) > *Products* > 3286

Other optional certificates are available on request.

## EU DECLARATION OF CONFORMITY



### Declaration of Conformity of Final Machinery

in accordance with Annex II, section 1. A. of the Directive 2006/42/EC

For the following products:

**Types 3281-1/-7 Pneumatic Control Valves consisting of the Type 3281 Valve and Type 3271/Type 3277 Pneumatic Actuator**

**Types 3286-1/-7 Pneumatic Control Valves consisting of the Type 3286 Valve and Type 3271/Type 3277 Pneumatic Actuator**

We hereby declare that the machinery mentioned above complies with all applicable requirements stipulated in Machinery Directive 2006/42/EC.

For product descriptions of the valve and actuator, refer to:

- Type 3281 Valve (DIN): Mounting and Operating Instructions EB 8251
- Type 3281 Valve (ANSI): Mounting and Operating Instructions EB 8252
- Type 3286 Valve (DIN): Mounting and Operating Instructions EB 8256
- Type 3286 Valve (ANSI): Mounting and Operating Instructions EB 8257
- Types 3271 and 3277 Actuators: Mounting and Operating Instructions EB 8310-X

Valve accessories (e.g. positioners, limit switches, solenoid valves, lock-up valves, supply pressure regulators, volume boosters and quick exhaust valves) are classified as machinery components in this declaration of conformity and do not fall within the scope of the Machinery Directive as specified in § 35 and § 46 of the Guide to Application of the Machinery Directive 2006/42/EC issued by the European Commission. In the SAMSON Manual H 02 titled "Appropriate Machinery Components for SAMSON Pneumatic Control Valves with a Declaration of Conformity of Final Machinery", SAMSON defines the specifications and properties of appropriate machinery components that can be mounted onto the above specified final machinery.

Referenced technical standards and/or specifications :

- VCI, VDMA, VGB: "Leitfaden Maschinenrichtlinie (2006/42/EG) - Bedeutung für Armaturen, Mai 2018" [German only]
- VCI, VDMA, VGB: "Zusatzdokument zum „Leitfaden Maschinenrichtlinie (2006/42/EG) - Bedeutung für Armaturen vom Mai 2018" [German only], based on DIN EN ISO 12100:2011-03

Comment:

Information on residual risks of the machinery can be found in the mounting and operating instructions of the valve and actuator as well as in the referenced documents listed in the mounting and operating instructions.

Persons authorized to compile the technical file:

SAMSON Controls, Inc., 4111 Cedar Boulevard, Baytown, Texas, USA  
Baytown, 14 November 2023

  
James Evans

Chief Operating Officer

  
David Tamm

Product Manager



## 15 Annex

### 15.1 Tightening torques, lubricants and tools

► AB 0100 for tools, tightening torques and lubricants

### 15.2 Spare parts

1	Body	39	Gasket
2	Bonnet (with connecting pipe)	42	Screw plug (test connection)
3	Yoke	44	Ring nut/ring
4	Seat	45	Packing ring
5	Plug	46	Seal
6	Nut	47	Support
7	Guide bushing	48	Screw
8	Threaded bushing	49	Screw
9	Stem connector nut	50	Threaded pin
10	Lock nut	51	Guide ring
11	Spring	52	Ring
12	Washer	53	Retaining ring
13	Stud bolt or expansion bolt	54	Pressure balancing (PTFE)
14	Body nut	55	Pressure balancing (graphite)
15	Packing assembly	60	Yoke assembly
16	V-ring packing	62	Flow divider ST 3
17	Gasket	63	Clamping element
19	Bushing	64	Gasket (shim)
21	Insulating section	65	Gasket (shim)
22	Bellows seal	67	Graphite fiber packing
24	Guide bushing	80	Nameplate
26	Label (bellows seal or insulating section)	81	Grooved pin
27	Flange	82	Screw
28	Clamping ring	83	Hanger
29	Plug for version with bellows seal	84	Travel indicator scale
31	Washer	91	Protective cap
32	Bolt	92	Castellated nut
33	Nut	93	Expansion sleeve
34	Screw	94	Expansion sleeve
37	Plug stem with metal bellows	101	Bonnet for version with bellows seal

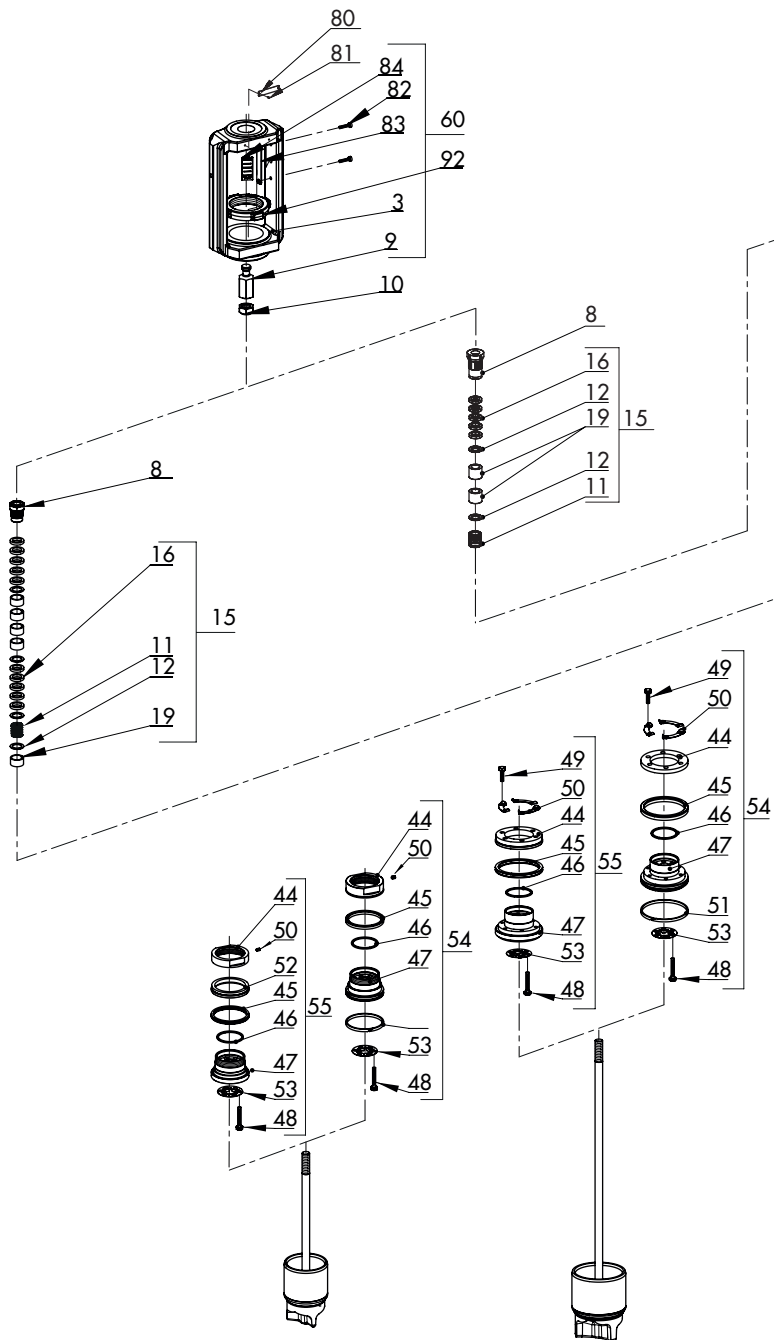

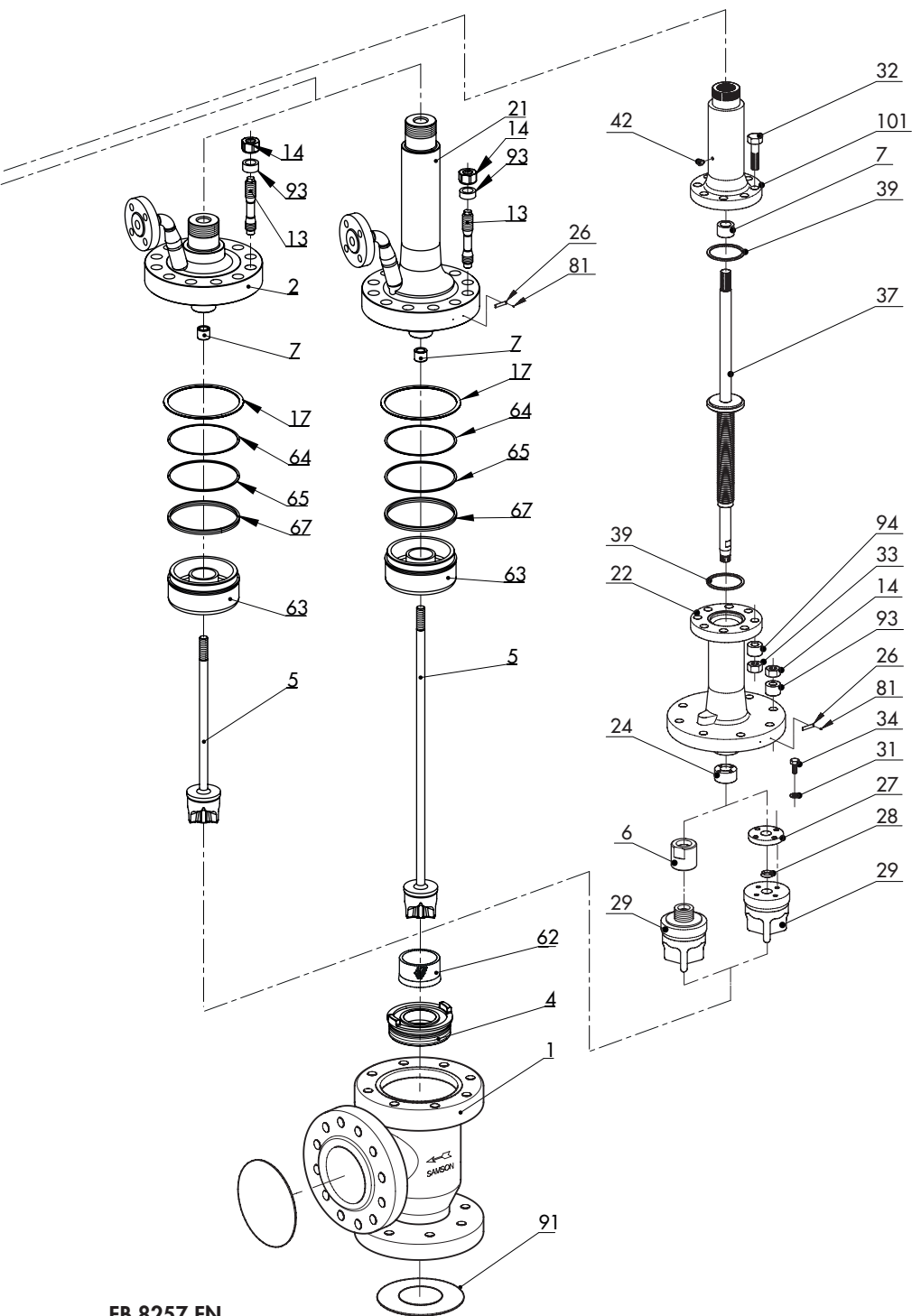

### 15.3 After-sales service

Contact our after-sales service for support concerning service or repair work or when malfunctions or defects arise.

#### E-mail address

You can reach our after-sales service at [aftersaleservice@samsongroup.com](mailto:aftersaleservice@samsongroup.com).

#### Addresses of SAMSON AG and its subsidiaries

The addresses of SAMSON AG, its subsidiaries, representatives and service facilities worldwide can be found on our website ([www.samsongroup.com](http://www.samsongroup.com)) or in all SAMSON product catalogs.

#### Required specifications

Please submit the following details:

- Order number and position number in the order
- Type, model number, valve size and valve version
- Pressure and temperature of the process medium
- Flow rate in cu.ft/min or m<sup>3</sup>/h
- Direction of flow
- Bench range of the actuator (e.g. 0.2 to 1 bar)
- Is a strainer installed?
- Installation drawing







**EB 8257 EN**



SAMSON AKTIENGESELLSCHAFT  
Weismüllerstraße 3 · 60314 Frankfurt am Main, Germany  
Phone: +49 69 4009-0 · Fax: +49 69 4009-1507  
samson@samsongroup.com · www.samsongroup.com